



**TRUE FOOD SERVICE EQUIPMENT, INC.**

St. Charles Industrial Center • P.O. Box 970 • O'Fallon, Missouri 63366  
 (636)240-2400 • FAX (636)272-2408 • (800)325-6152 • www.truemfg.com  
 Parts Dept. (800)424-TRUE • Parts Dept. FAX# (636)272-9471

Project Name: \_\_\_\_\_

A/A #

Location: \_\_\_\_\_

Item #: \_\_\_\_\_ Qty: \_\_\_\_\_

SIS #

Model #: \_\_\_\_\_

Model:  
**TM-52G**

**TM Series:**  
*Reach-In Top Mount Glass Door Refrigerator*



**TM-52G**

- ▶ True's glass door reach-in's are designed with enduring quality that protects your long term investment.
- ▶ Designed using the highest quality materials and components to provide the user with colder product temperatures, lower utility costs, exceptional food safety and the best value in today's food service marketplace.
- ▶ Oversized, factory balanced, refrigeration system holds 33°F to 38°F (.5°C to 3.3°C) for the best in food preservation.
- ▶ Energy efficient, "Low-E," double pane thermal glass doors.
- ▶ Adjustable, heavy duty PVC coated shelves.
- ▶ Positive seal self-closing doors. Lifetime guaranteed door hinges and torsion type closure system.
- ▶ Entire cabinet structure is foamed-in-place using high density, CFC free, polyurethane insulation.

**ROUGH-IN DATA**

Specifications subject to change without notice.

Chart dimensions rounded up to the nearest 1/8" (millimeters rounded up to next whole number).

Model	Glass Doors	Capacity (Cu. Ft.) (liters)	# of Shelves	Cabinet Dimensions (inches) (mm)			HP	Voltage	Amps	NEMA Config.	Cord Length (total ft.) (total m)	Crated Weight (lbs.) (kg)
				L	D†	H*						
TM-52G	2	52 1473	6	54 1/8 1375	29 3/4 756	78 1/4 1988	1/2	115/60/1	10.0	5-15P	9 2.74	512 233

† Depth does not include 1 3/8" (35 mm) for door handles.

\* Height does not include 5" (127 mm) for castors or 6" (153 mm) for optional legs.



**APPROVALS:**

Model:  
**TM-52G**

**TM Series:**  
Reach-In Top Mount Glass Door Refrigerator



## STANDARD FEATURES

### DESIGN

- True's commitment to using the highest quality materials and oversized refrigeration systems provides the user with colder product temperatures, lower utility costs, exceptional food safety and the best value in today's food service marketplace.

### REFRIGERATION SYSTEM

- Factory engineered, self-contained, capillary tube system using environmentally friendly (CFC free) 134A refrigerant.
- Extra large evaporator coil balanced with higher horsepower compressor and large condenser; maintains 33°F to 38°F (.5°C to 3.3°C) for the best in food preservation.
- Sealed, cast iron, self-lubricating evaporator fan motors and larger fan blades give True reach-in's a more efficient low velocity, high volume airflow design. This unique design insures faster temperature recovery and shorter run times in the busiest of food service environments.
- Top mounted condensing unit.

### CABINET CONSTRUCTION

- Exterior - 300 series stainless steel front grill and shroud. Anodized quality aluminum exterior ends and back.
- Interior - attractive, NSF approved, white aluminum liner. 300 series stainless floor with coved corners.
- Insulation - entire cabinet structure is foamed-in-place using high density, CFC free, polyurethane insulation.

- Cabinet mounted on a welded, heavy duty galvanized frame rail. Rail dipped in rust inhibiting enamel paint for corrosion protection inside and out.
- Frame rail fitted with 4" (102 mm) diameter stem castors - locks provided on front set.

### DOORS

- "Low-E," double pane thermal glass assemblies with extruded aluminum frames. Door locks standard.
- Positive seal self-closing doors. Lifetime guaranteed door hinges and torsion type closure system.
- Each door fitted with 15" (381 mm) long extruded aluminum handle.
- Magnetic door gaskets of one piece construction, removable without tools for ease of cleaning.

### SHELVING

- Six (6) adjustable, heavy duty PVC coated wire shelves 24<sup>9</sup>/<sub>16</sub>" L x 22<sup>3</sup>/<sub>8</sub>" D (624 mm x 569 mm). Four (4) chrome plated shelf clips included per shelf.
- Shelf support pilasters made of same material as cabinet interior; shelves are adjustable on 1/2" (13 mm) increments.

### LIGHTING

- Fluorescent interior lighting. Each glass door utilizes full-length, patented, intergrated door light (IDL) system. Safety shielded.

### MODEL FEATURES

- Evaporator is epoxy coated to eliminate the potential of corrosion.
- Exterior mounted temperature monitor.
- NSF-7 compliant for open food product.

### ELECTRICAL

- Unit completely pre-wired at factory and ready for final connection to a 115/60/1 phase - 15 amp dedicated outlet. Cord and plug set included.



115/60/1  
NEMA-5-15R

### OPTIONAL FEATURES/ACCESSORIES

Upcharge and lead times may apply.

- 6" (153 mm) standard legs.
- 6" (153 mm) seismic/flanged legs.
- Additional shelves.
- Half door bun tray racks. Holds up to eleven 18" L x 26" D (458 mm x 661 mm) sheet pans (sold separately).
- Full door bun tray racks. Holds up to twenty-two 18" L x 26" D (458 mm x 661 mm) sheet pans (sold separately).
- Novelty baskets.
- Remote cabinets (condensing unit supplied by others), consult factory technical service department for BTU information.

## PLAN VIEW

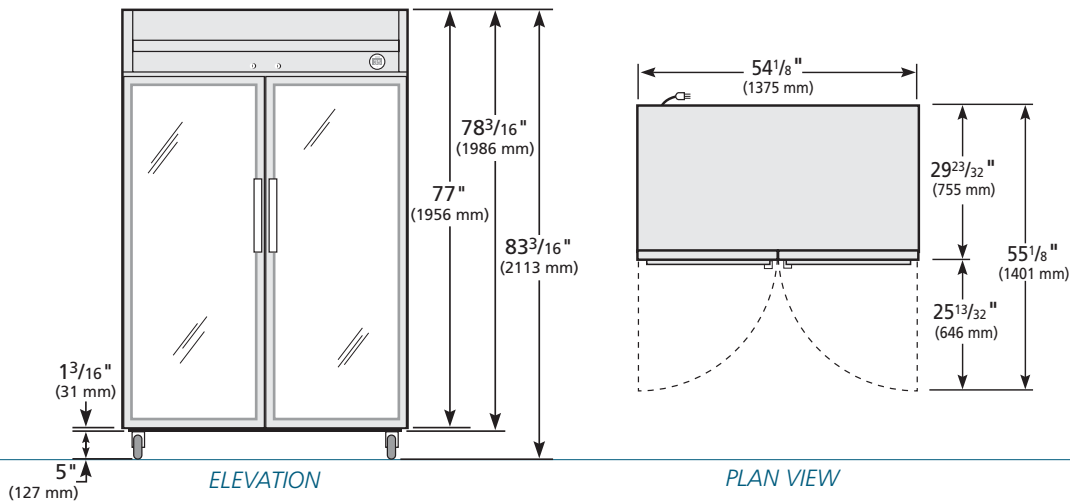

**WARRANTY**  
One year warranty on all parts & labor and an additional 4 year warranty on compressor. (U.S.A. only)

METRIC DIMENSIONS ROUNDED UP TO THE NEAREST WHOLE MILLIMETER  
SPECIFICATIONS SUBJECT TO CHANGE WITHOUT NOTICE



Model	Elevation	Right	Plan	3D
TM-52G	TFEY71E	TFEY71S	TFEY71P	TFEY713

## TRUE FOOD SERVICE EQUIPMENT

St. Charles Industrial Center • P.O. Box 970 • O'Fallon, Missouri 63366 • (636)240-2400 • FAX (636)272-2408 • (800)325-6152 • www.truemfg.com