



**TRUE FOOD SERVICE EQUIPMENT, INC.**

St. Charles Industrial Center • P.O. Box 970 • O'Fallon, Missouri 63366  
 (636)240-2400 • FAX (636)272-2408 • (800)325-6152 • www.truemfg.com  
 Parts Dept. (800)424-TRUE • Parts Dept. FAX# (636)272-9471

Project Name: \_\_\_\_\_

Location: \_\_\_\_\_

Item #: \_\_\_\_\_ Qty: \_\_\_\_\_

Model #: \_\_\_\_\_

A/A #

S/S #

Model:  
**TCGR-77**

**Display Case:**  
*Curved Glass Refrigerated Bakery Case*



**TCGR-77**

- ▶ True's refrigerated bakery case combines efficient, high volume merchandising and exceptional refrigeration with an elegant curved glass front for sophisticated presentation of high end desserts and pastries.
- ▶ Self-contained, environmentally friendly (CFC free) 134A refrigeration system.
- ▶ More efficient low velocity, high volume airflow design maintains 38°F to 40°F (3.3°C to 4.4°C) without drying out product. Ideally suited for delicate bakery products.
- ▶ Cabinet is NSF-7 certified to hold open food product.
- ▶ Insulated, double pane curved glass front and side glass panels provide extra large viewing area to maximize bakery product presentation. Front glass tilts forward for easy cleaning.
- ▶ Three (3) adjustable PVC coated shelves.
- ▶ Low UV emitting fluorescent lighting system.
- ▶ Front and sides standard with white laminate panels, five additional color options available at no charge. Stainless steel top.

**ROUGH-IN DATA**

Specifications subject to change without notice.

Chart dimensions rounded up to the nearest 1/8" (millimeters rounded up to next whole number).

Model	Doors	Capacity (Cu. Ft.) (liters)	Shelves	Cabinet Dimensions (inches) (mm)			HP	Voltage	NEMA Config.	Amps	Crated Weight (lbs.) (kg)
				L	D	H					
TCGR-77	2	37.2 1054	3	77 <sup>7</sup> / <sub>8</sub> 1979	35 <sup>1</sup> / <sub>2</sub> 902	47 <sup>7</sup> / <sub>8</sub> 1217	<sup>3</sup> / <sub>4</sub>	115/60/1	5-20P	15.5	820 372

10/05 Printed in U.S.A.

**APPROVALS:**

**AVAILABLE AT:**

Model:  
**TCGR-77**

**Display Case:**  
*Curved Glass Refrigerated Bakery Case*



**STANDARD FEATURES**

**DESIGN**

- True's refrigerated bakery case combines efficient, high volume merchandising and exceptional refrigeration with an elegant curved glass front for sophisticated presentation of high end desserts and pastries.
- Designed to provide an attractive companion to our "dry" display case.

**REFRIGERATION SYSTEM**

- Self-contained, factory pre-engineered capillary tube system using environmentally friendly (CFC free) 134A refrigerant.
- Extra large evaporator coil balanced with higher horsepower compressor and large condenser maintains 38°F to 40°F (3.3°C to 4.4°C), ideally suited for bakery products.
- Forced-air refrigeration system; sealed, cast iron, self-lubricating evaporator fan motor and larger fan blades give True refrigerated bakery cases a more efficient low velocity, high volume airflow design.
- Condensing unit located behind removable panel in back of unit. Entire system slides out for easy cleaning and maintenance.

**CABINET CONSTRUCTION**

- Exterior - white laminate front and side panels. Color options available at no charge.



Walnut | Teak | Oak | Beige | Black | White  
All laminate ships separately from unit and are field installed. Stainless steel top. Black front and rear grills and trim.

- Insulated, double pane curved glass front and side panels provide extra large viewing area to maximize bakery product presentation.
- Front glass tilts forward for easy cleaning. Exterior pane is tempered for safety.

- Interior - NSF approved white aluminum sides and top, high impact plastic floor with coved corners.
- Insulation - entire cabinet structure is foamed-in-place using high density, CFC free, polyurethane insulation.
- Cabinet mounted on a welded, heavy duty galvanized frame rail. Rail dipped in rust inhibiting enamel paint for corrosion protection inside and out. Leg levelers included.

**DOORS**

- "Low-E", double pane thermal glass insert with mitered plastic channel frame.
- Self-closing rear doors, efficient elastic tubing closure mechanism for smooth, even, positive closure. Sliding doors ride on stainless steel V-channel with stainless steel bearings. Doors fit within plastic channel frame.
- Each door is fitted with a 12" (305 mm) long molded plastic handle.

**SHELVING**

- Three (3) adjustable, heavy duty PVC coated wire shelves 71<sup>3</sup>/<sub>8</sub>" L x 22<sup>1</sup>/<sub>2</sub>" D (1813 mm x 572 mm). Shelving system is cantilevered and angle can be adjusted to maximize presentation.
- Shelf supports a maximum weight of 150 lbs. (69 kg).

**PAN CAPACITY**

- Cabinet holds (16) 18" L x 26" D (458 mm x 661 mm) display pans (4 per level). Pans supplied by others.

**LIGHTING**

- Case is equipped with 4 light sources for maximum product display; three (3) shelf mounted and one (1) cabinet mounted. Fluorescent lamps are low UV emitting to enhance product appearance and increase shelf life.

- Safety shielded lighting tube assure longer, brighter, shadow-free product illumination.

**MODEL FEATURES**

- Evaporator is epoxy coated to eliminate the potential of corrosion.
- Recessed exterior light switch and thermostat control.
- NSF-7 compliant for open food product.

**ELECTRICAL**

- Unit completely pre-wired at factory and ready for final connection to a 115/60/1 phase - 20 amp dedicated outlet. Cord and plug set included.



115/60/1  
NEMA-5-20R

**RECOMMENDED OPERATION CONDITIONS**

- TCGR models are designed to operate in an environment where temperature and humidity do not exceed 75°F (24°C) and 55% relative humidity.

**OPTIONAL FEATURES/ACCESSORIES**

Upcharge and lead times may apply.

- Custom exterior laminates, contact factory for details. See our website: [www.truemfg.com](http://www.truemfg.com) for the latest color offerings.
- Additional shelves (contact factory).
- Remote cabinets (condensing units supplied by others; system comes standard with 404A expansion valve and requires R404A refrigerant). Consult factory technical service department for BTU information.

**PLAN VIEW**

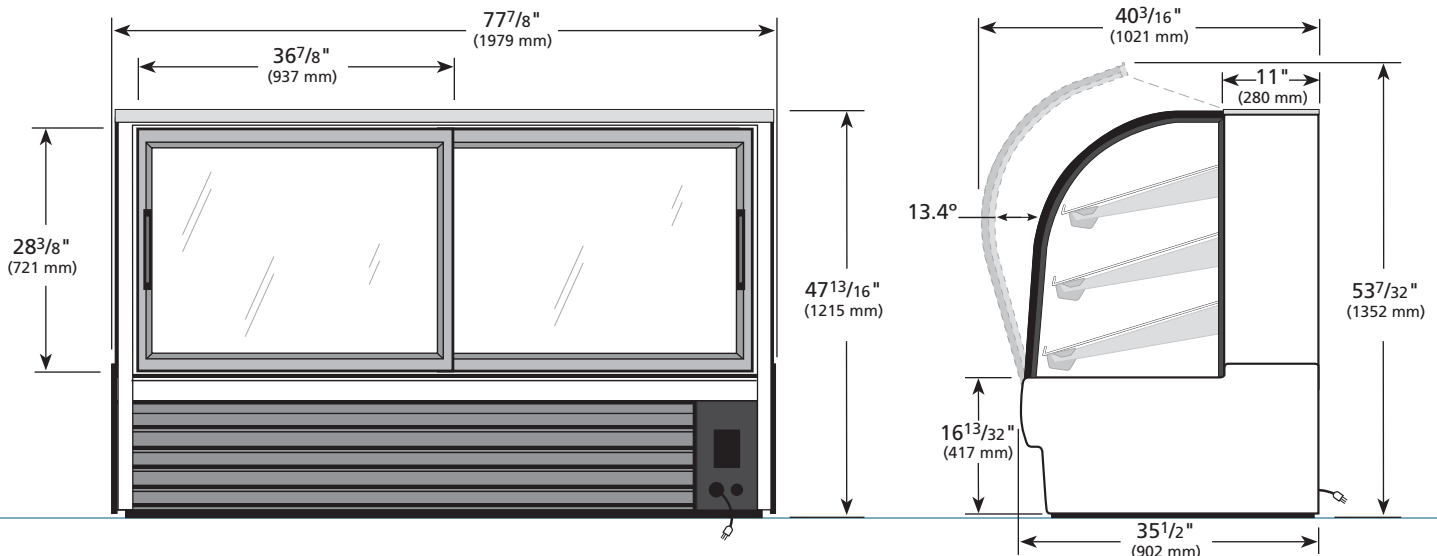

**WARRANTY**  
One year warranty on all parts & labor and an additional 4 year warranty on compressor. (U.S.A. only)

METRIC DIMENSIONS ROUNDED UP TO THE NEAREST WHOLE MILLIMETER  
SPECIFICATIONS SUBJECT TO CHANGE WITHOUT NOTICE

	Model	Elevation	Right	Plan	3D	Back
	TCGR-77	TFD066E	TFD055S	TFD066P	TFD0663	TFD066B

**TRUE FOOD SERVICE EQUIPMENT**