



TRUE FOOD SERVICE EQUIPMENT, INC.

2001 East Terra Lane • P.O. Box 970 • O'Fallon, Missouri 63366
(636)240-2400 • Fax (636)272-2408 • (800)325-6152 • Intl Fax# (001)636-272-7546
Parts Dept. (800)424-TRUE • Parts Dept. Fax# (636)272-9471 • www.truemfg.com

Project Name: _____

A/A #

Location: _____

Item #: _____ Qty: _____

SIS #

Model #: _____

Model:
TCGD-77

Display Case:
Curved Glass "Dry" Case



TCGD-77

- ▶ True's non-refrigerated "dry" bakery display case combines efficient, high volume merchandising with an elegant curved glass front for sophisticated presentation of breads, desserts and pastries.
- ▶ Cabinet is NSF-2 certified to hold open food product.
- ▶ Single pane curved glass front and side panels provide extra large viewing area to maximize bakery product presentation. Front glass tilts forward for easy cleaning.
- ▶ Three (3) adjustable PVC coated shelves.
- ▶ Special "brown bulb" lighting provides balanced color spectrum that enhances the appearance of bakery products.
- ▶ Exterior front and sides standard with white laminated panels, five additional color options available at no charge. All laminate ships separately from unit and are field installed. Stainless steel top.
- ▶ White aluminum interior sides and top. High impact plastic floor with coved corners.

ROUGH-IN DATA

Specifications subject to change without notice.
Chart dimensions rounded up to the nearest 1/8" (millimeters rounded up to next whole number).

Model	Doors	Capacity (Cu. Ft.) (liters)	Shelves	Cabinet Dimensions (inches) (mm)			Voltage	Amps	Crated Weight (lbs.) (kg)
				L	D†	H			
TCGD-77	2	37 1048	3	77 ⁷ / ₈ 1979	35 ¹ / ₂ 902	47 ⁷ / ₈ 1217	115/60/1	6.4	630 286

† Depth does not include 3/4" (18 mm) for door handles.



6/07

Printed in U.S.A.

APPROVALS:

AVAILABLE AT:

Model:
TCGD-77

Display Case:
Curved Glass "Dry" Case



STANDARD FEATURES

DESIGN

- True's "dry" display case combines efficient, high volume merchandising with an elegant curved glass front for sophisticated presentation of breads, desserts and pastries.
- Designed to provide an attractive companion to our forced-air refrigerated display case.

CABINET CONSTRUCTION

- Exterior - white laminate front and side panels. Color options available at no charge.



Walnut | Teak | Oak | Beige | Black | White

- All laminates ship separately from unit and are field installed. Stainless steel top. Black front grill and trim. Template kit available at no charge for field customization of laminate.
- Interior - NSF approved white aluminum sides and top; high impact plastic floor with coved corners.
- Welded, heavy duty galvanized frame rail dipped in rust inhibiting enamel paint for corrosion protection inside and out.
- Frame rail fitted with leg levelers.

CURVED FRONT DISPLAY GLASS

- Single pane curved glass front and side panels provide extra large viewing area to maximize bakery product presentation. Glass is tempered for safety.

- Front glass tilts forward for easy cleaning.

REAR DOORS

- "Low-E", double pane thermal glass rear door inserts with mitered plastic channel frames.
- Each door fitted with 12" (305 mm) long molded plastic handle.
- Self-closing doors, efficient counter balanced weight system for smooth, even, positive closure. Sliding doors ride on stainless steel V-Channel with stainless steel bearings. Doors fit within plastic channel frame.

SHELVING

- Three (3) adjustable, heavy duty PVC coated wire shelves 71³/₈" L x 22¹/₂" D (1813 mm x 572 mm). Shelving system is cantilevered and angle can be adjusted to maximize presentation.
- Each shelf supports a maximum weight of 150 lbs. (69 kg).

PAN CAPACITY

- Cabinet holds sixteen (16) 18" L x 26" D (458 mm x 661 mm) display pans (4 per level). Pans supplied by others.

LIGHTING

- Cabinet equipped with 4 light sources for maximum product display; three (3) shelf mounted and one (1) cabinet mounted. Special "brown bulb" lighting provides balanced color spectrum that enhances the appearance of bakery products.

- Safety shielded lighting tubes assure longer, brighter, shadow-free product illumination.

MODEL FEATURES

- 5 Amp exterior scale receptacle.
- Recessed exterior light switch.
- NSF-2 compliant for open food product.

ELECTRICAL

- Unit comes with 4 feed wires (including ground) to be hardwired at installation site to a 115/60/1 phase, 15 amp dedicated outlet.

OPTIONAL FEATURES/ACCESSORIES

Upcharge and lead times may apply.

- 12" (305 mm) cord set (factory installed). Exterior scale receptacle will not be included with this option.
- Custom exterior laminates, contact factory for details. See our website: www.truemfg.com for the latest color offerings.
- Stainless steel exterior.
- Mirrored interior ends with laminate exterior.
- Additional lighted shelves.
- Additional non-lighted shelves.

PLAN VIEW

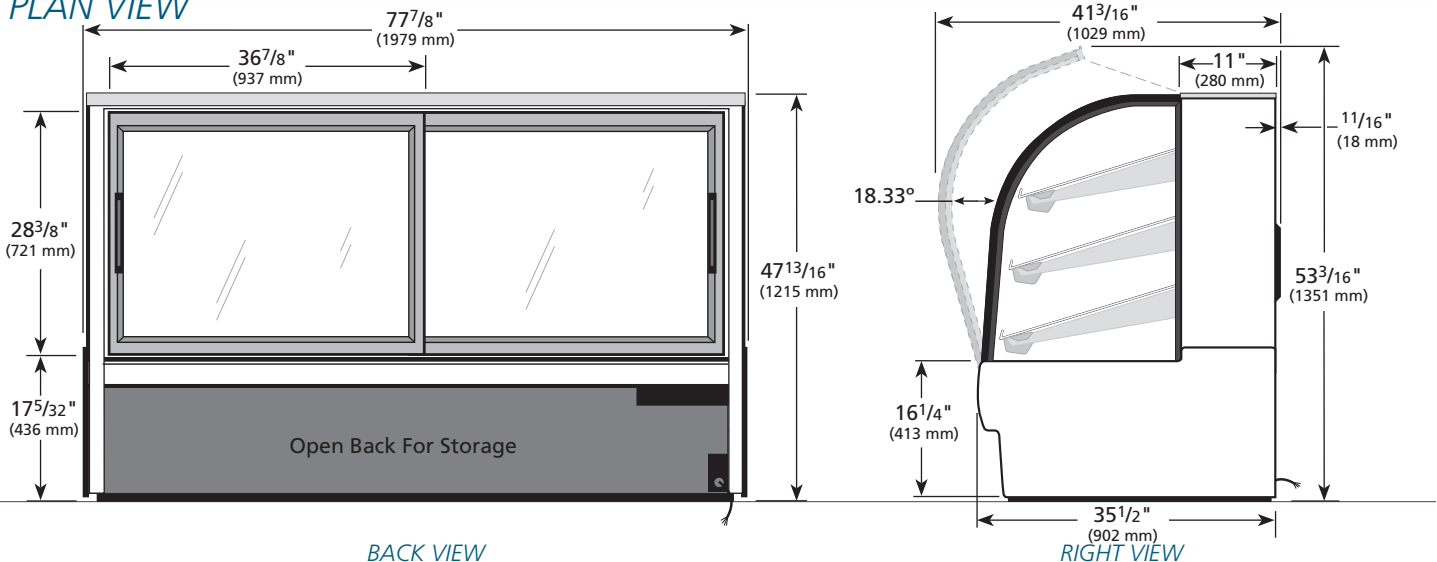

WARRANTY

One year warranty on all parts and labor and an additional 4 year warranty on compressor. (U.S.A. only)

METRIC DIMENSIONS ROUNDED UP TO THE NEAREST WHOLE MILLIMETER
SPECIFICATIONS SUBJECT TO CHANGE WITHOUT NOTICE



Model	Elevation	Right	Plan	3D	Back
TCGD-77	TFD067E	TFD055S	TFD067P	TFD0673	TFD067B

TRUE FOOD SERVICE EQUIPMENT

2001 East Terra Lane • P.O. Box 970 • O'Fallon, Missouri 63366 • (636)240-2400 • Fax (636)272-2408 • (800)325-6152 • Intl. Fax# (001)636-272-7546 • www.truemfg.com