



TRUE FOOD SERVICE EQUIPMENT, INC.

2001 East Terra Lane • P.O. Box 970 • O'Fallon, Missouri 63366
 (636)240-2400 • Fax (636)272-2408 • (800)325-6152 • Intl Fax# (001)636-272-7546
 Parts Dept. (800)424-TRUE • Parts Dept. Fax# (636)272-9471 • www.truemfg.com

Project Name: _____

A/A #

Location: _____

Item #: _____ Qty: _____

SIS #

Model #: _____

Model:
GEM-23

Glass Door Merchandisers:
Glass End Refrigerator



GEM-23

- ▶ Glass end models offer greater product visibility for more attractive displays.
 - ▶ Oversized, factory balanced, refrigeration system holds 33°F to 38°F (.5°C to 3.3°C).
 - ▶ Exterior - non-peel or chip white laminated vinyl; durable and permanent.
 - ▶ Interior - attractive, NSF approved, white aluminum interior liner with 300 series stainless steel floor.
 - ▶ Self closing door. Positive seal, torsion type closure system.
 - ▶ "Low-E", double pane thermal glass side panels and door assemblies. The latest in energy efficient technology.
 - ▶ Safety shielded fluorescent interior lighting. Door utilizes full-length, patented, integrated door light (IDL) system.
 - ▶ Illuminated exterior sign panel. Variety of sign options available.
 - ▶ Entire cabinet structure is foamed-in-place using high density, CFC free, polyurethane insulation.
- Bottom mounted units feature**
- ▶ "No stoop" lower shelf to maximize product visibility
 - ▶ Storage on top of cabinet.
 - ▶ Easily accessible condenser coil for cleaning.

ROUGH-IN DATA

Specifications subject to change without notice.
 Chart dimensions rounded up to the nearest 1/8" (millimeters rounded up to next whole number).

Model	Doors	Capacity (Cu. Ft.) (liters)	Shelves	Cabinet Dimensions (inches) (mm)			HP	Voltage	Amps	NEMA Config.	Cord Length (total ft.) (total m)	Crated Weight (lbs.) (kg)
				L	D†	H						
GEM-23	1	23 652	4	27 686	29 7/8 759	78 5/8 1998	1/3 1/3	115/60/1 230-240/50/1	7.2 3.0	5-15P ▲	9 2.74	375 171

† Depth does not include 1 1/8" (29 mm) for door handle.

▲ Plug type varies by country.



APPROVALS:

AVAILABLE AT:

Model:
GEM-23

Glass Door Merchandiser:
Glass End Refrigerator



STANDARD FEATURES

DESIGN

- The world's #1 manufacturer of glass door merchandisers.
- True's commitment to using the highest quality materials and oversized refrigeration systems provides the user with colder product temperatures, and lower utility costs in an attractive merchandiser that brilliantly displays packaged food and beverages.

REFRIGERATION SYSTEM

- Factory engineered, self-contained, capillary tube system using environmentally friendly (CFC free) 134A refrigerant.
- Extra large evaporator coil balanced with higher horsepower compressor and large condenser; maintains cabinet temperatures of 33°F to 38°F (.5°C to 3.3°C).
- Sealed, cast iron, self-lubricating evaporator fan motor(s) and larger fan blades give True merchandisers a more efficient low velocity, high volume airflow design. This unique design insures faster temperature pull down of warm product, colder holding temperatures and faster recovery in high use situations.
- Bottom mounted condensing unit positioned for easy maintenance; "no stoop" lower shelf maximizes visibility by raising merchandised product to a higher level.

CABINET CONSTRUCTION

- Exterior - non-peel or chip white laminated vinyl; durable and permanent.
- Glass ends - Low-E, double pane thermal glass assemblies. The latest in energy efficient technology.
- Interior - attractive, NSF approved, white aluminum liner with 300 series stainless steel floor.

- Insulation - entire cabinet structure is foamed-in-place using high density, CFC free, polyurethane insulation.
- Welded, heavy duty galvanized frame rail dipped in rust inhibiting enamel paint for corrosion protection inside and out.
- Frame rail fitted with leg levelers.
- Illuminated exterior sign panel. Variety of sign options available.

DOOR

- "Low-E", double pane thermal glass door assembly with extruded aluminum frame. The latest in energy efficient technology.
- Door fitted with 15" (381 mm) long PVC handle.
- Self closing door. Positive seal, torsion type closure system.
- Magnetic door gasket of one piece construction, removable without tools for ease of cleaning.

SHELVING

- Four (4) adjustable, heavy duty, white PVC coated wire shelves 22⁹/₁₆" L x 22¹/₄" D (574 mm x 566 mm). Four (4) chrome plated shelf clips included per shelf.
- Shelf support pilasters made of same material as cabinet interior; shelves are adjustable on 1/2" (13 mm) increments.

LIGHTING

- Safety shielded fluorescent interior lighting. Door utilizes full-length, patented, integrated door light (IDL) system.
- Cabinet lighting utilizes electronic ballast and T-8 bulbs for brighter illumination, longer bulb life and increased energy efficiency.

MODEL FEATURES

- Evaporator is epoxy coated to eliminate the potential of corrosion.

- See our website www.truemfg.com for latest color and sign offerings.
- Convenient clean-out drain built in cabinet floor.
- Listed under NSF-7 for the storage and/or display of packaged or bottled product.

ELECTRICAL

- Unit completely pre-wired at factory and ready for final connection to a 115/60/1 phase 15 amp dedicated outlet. Cord and plug set included.



115/60/1
NEMA-5-15R

OPTIONAL FEATURES/ACCESSORIES

Upcharge and lead times may apply.

- 230-240V / 50 Hz.
- Black exterior.
- Rosewood exterior.
- Copper exterior.
- Black aluminum interior liner with black shelving.
- 6" (153 mm) standard legs.
- 6" (153 mm) seismic/flanged legs.
- 2 1/2" (64 mm) diameter castors.
- Barrel locks (factory installed).
- Additional shelves.
- Black shelves.
- Novelty baskets.
- TrueTrac4 gravity feed organizers.
- 1 1/4" (32 mm) pricing strips.
- Red wine thermostat.
- Chocolate thermostat.
- White wine thermostat.
- Remote cabinets (condensing unit supplied by others; system comes standard with 404A expansion valve and requires R404A refrigerant). Consult factory technical service department for BTU information.

PLAN VIEW

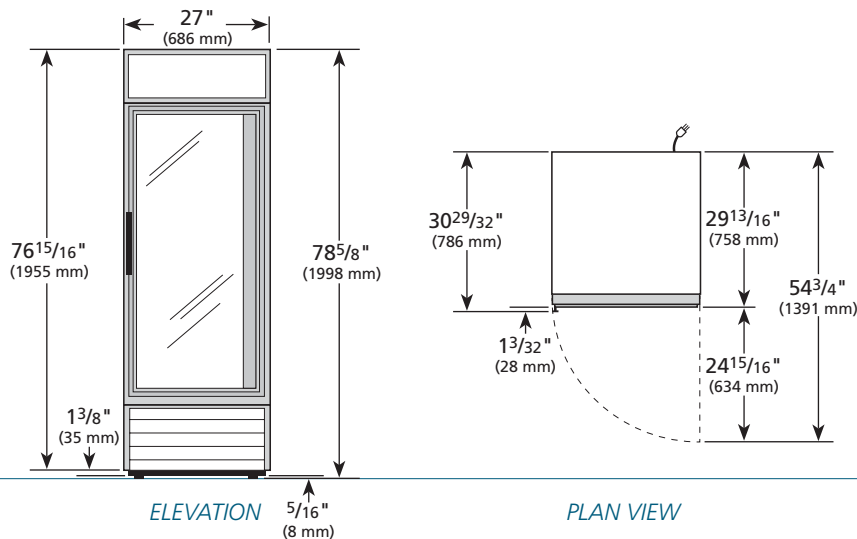

WARRANTY
One year warranty on all parts and labor and an additional 4 year warranty on compressor. (U.S.A. only)

METRIC DIMENSIONS ROUNDED UP TO THE NEAREST WHOLE MILLIMETER
SPECIFICATIONS SUBJECT TO CHANGE WITHOUT NOTICE



Model	Elevation	Right	Plan	3D
GEM-23	TFAY10E	TFAZ10S	TFAZ10P	TFAZ103

TRUE FOOD SERVICE EQUIPMENT