



STAR-MAX™ RADIANT STYLE GAS CHAR-BROILERS

Models 6115RCBD, 6124RCBD, 6136RCBD & 6148RCBD

Features/Benefits:

- ★ Star-Max™ Radiant Gas Char-Broilers are designed for the most demanding foodservice applications. Star-Max™ char-broilers deliver maximum performance and provide years of maintenance free operation.
- ★ Available in 15", 24", 36" and 48" widths to fit many foodservice operation's space requirements.
- ★ Designed with high performance 40,000 BTU H-style cast iron burners every 12" of width. Cast iron burners provide excellent broiling performance, better heat distribution and maximum sectional control.
- ★ Heavy-duty cast iron grates can be individually positioned (flat or slanted) to accommodate a variety of broiling needs. Plus, our grates are reversible with a thin side for searing and a thick side for more delicate menu items.
- ★ Large capacity stainless steel water pan for easy clean up.
- ★ Stainless steel, 2-3/4" high tapered splash guard provides maximum protection against grease and spills.
- ★ Cool to the touch stainless steel bull nose front provides knob protection and comfortable work zone.
- ★ Gas convertible in the field with conversion kit supplied with each char-broiler. Units are shipped Natural Gas.
- ★ Heavy-duty 4 " adjustable legs to match the height of other Star-Max™ equipment in your line.



Model 6136RCBD



**Model 6148RCBD
with Optional Equipment Stand**

Applications:

Star-Max™ radiant char-broilers are designed for high volume and reliability. Whether it's steak, chicken, hamburger, shish kabobs or other menu items; Star-Max™ char-broilers will fulfill your menu requirements and more!

Quality Construction:

Star-Max™ line of radiant char-broilers feature stainless steel front panel, bull nose, drip pan, splash guard, and grease trough. Char-broilers have heavy-duty polycarbonate graphic panel. Double wall aluminized steel side panels with cast iron burners every 12", adjustable valves and standing pilot are standard. Radiants are stainless steel providing maximum heat transfer and durability. Cooking surface consists of heavy duty, cast iron grates adjustable to flat or slanted positions.

Warranty:

Star-Max™ Radiant Char-broilers are covered by a one year parts and labor warranty.





STAR-MAX™ RADIANT STYLE GAS CHAR-BROILERS

Models 6115RCBD, 6124RCBD, 6136RCBD & 6148RCBD

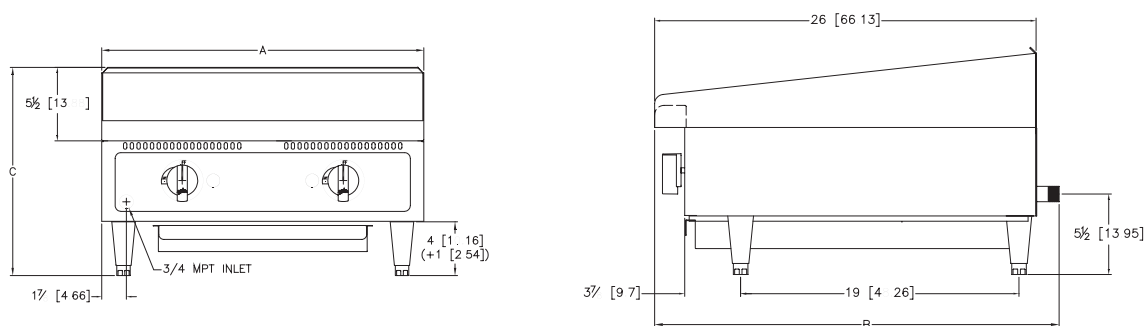

Specifications

Model No.	Dimensions			No. Controls	BTU	Grid Area	Approximate Weight	
	(A) Width Inches (cm)	(B) Depth Inches (cm)	(C) Height Inches (cm)				Installed lb. (kg)	Shipping lb. (kg)
6115RCBD	15 (38.1)	25-3/4 (65.4)	15-1/2 (39.4)	1	*40,000	300 sq. in. (1935 sq. cm)	80 (36.4)	88 (40.0)
6124RCBD	24 (61.0)	25-3/4 (65.4)	15-1/2 (39.4)	2	*80,000	480 sq. in. (3097 sq. cm)	140 (63.5)	155 (70.3)
6136RCBD	36 (91.4)	25-3/4 (65.4)	15-1/2 (39.4)	3	*120,000	720 sq. in. (4645 sq. cm)	220 (100.0)	240 (109.0)
6148RCBD	48 (121.9)	25-3/4 (65.4)	15-1/2 (39.4)	4	*160,000	960 sq. in. (6194 sq. cm)	300 (136.0)	325 (147.7)

*Units operate on Natural or Propane Gas - On propane gas 35,000 BTU/HR for every 12" (30.5 cm) width.

Typical Specifications

Gas char-broilers are constructed with stainless steel front panel with black polycarbonate trim and double wall aluminized steel side panels. Unit are 40,000 BTU (35,000 BTU on propane gas) cast iron burner for every 12" (30.5 cm) of width and is controlled by an adjustable valve. Two stainless steel radiants per burner are provided. Cooking surface is a heavy duty cast iron grate type that is adjustable in height. A stainless steel water pan is provided. Control knobs are protected by a stainless steel bull nose front. A standing pilot is provided. Char-broilers are supplied with 4" (10.2 cm) high die cast nickel plated legs that have a 1-3/8" (3.5 cm) adjustment. Gas connection is 3/4" N.P.T. male and a convertible pressure regulator is provided. Units are AGA Certified and NSF and CGA listed. Printed in the U.S.A.