



QCS BAGEL FAST CONVEYOR TOASTERS

Models QCS2-1200B & QCS3-1600B

QCS Features/Benefits:

- ★ Holman's forced convection system keeps the toaster cool to the touch and extends the life of critical components. The forced convection increases productivity by circulating pre-heated air into toasting chamber.
- ★ Quartz infrared heaters provide faster, more consistent heating than traditional heating elements and toasts bagels and English muffins in seconds!
- ★ Space saving design - our forced convection system allows the unit to be placed against a wall. Other toasters have louvers requiring additional counter space.
- ★ High performance -
QCS2-1200B produces 1200 bagel halves per hour.
QCS3-1600B produces up to 1600 bagel halves per hour.
- ★ Easy to use control panel takes the guesswork out of speed control settings.
- ★ Toasts bagels and English muffins in seconds!
- ★ Variable speed control for perfect color and texture of bagels and English muffins!
- ★ Energy efficient operation with power saver switch that reduces electricity consumption by 75%. Plus our quartz heaters return to full power in seconds vs. minutes for metal-sheathed elements.
- ★ Extended conveyor belt for easy loading and large warming area for higher production.
- ★ Safe load up area with full width front burn guard and cool to the touch exterior.
- ★ "Smart" crumb tray keeps the breadcrumbs from falling under the toaster.
- ★ Heated holding area to keep toast at the perfect temperature.
- ★ Hi-limit switch prevents toaster from overheating protecting critical component parts.
- ★ 24 hours 7 days a week technical support by Star technicians.



QCS2-1200B



QCS3-1600B

Applications:

Bagels - toast perfectly every time with Holman high quality bagel toasters. Choose from our most popular QCS2-1200B for toasting bagels all day. Or if you really need a high volume bagel toaster, consider our QCS3-1600B.

Quality Construction:

No matter how you slice it, Holman delivers high quality, reliable toasters. Stainless steel construction for long lasting durability. Heavy-duty motor, drive chain and conveyor speed control for superior reliability. Conveyor belt tension system for smooth and quiet operation. High performance quartz infrared heaters for superior toasting performance and reliability. Units are easy to disassemble with one-piece cover for cleaning and service. Toasters are furnished with 1" adjustable legs and 4' cord.

Warranty:

Holman's conveyor toasters are covered by a one-year parts and labor warranty.





QCS BAGEL FAST CONVEYOR TOASTERS

Models QCS2-1200B & QCS3-1600B

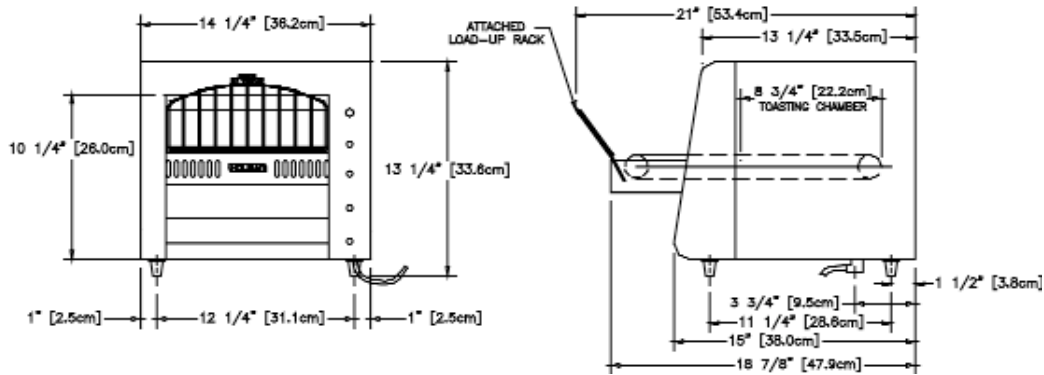

Performance Data

Model No.	Production Capacities	Product Opening
QCS2-1200B	Up to 1,200 bagel halves per hour	1-3/4"
QCS3-1600B	Up to 1,600 bagel halves per hour	1-3/4"

Specifications

Model No	Dimensions			Shipping Weight lbs. (kg)	Shipping Carton		
	Width Inches (cm)	Depth Inches (cm)	Height Inches (cm)		Width Inches (cm)	Depth Inches (cm)	Height Inches (cm)
QCS2-1200B	14-1/2" (36.8)	22-3/8" (56.8)	15-5/8" (39.7)	64 (140.8)	20" (50.8)	18-7/8" (47.9)	25-3/8" (64.4)
QCS3-1600B	18-1/2" (47)	22-3/8" (56.8)	15-5/8" (39.7)	68 (149.6)	22-3/4" (57.7)	19-3/4" (50.1)	25-3/8" (64.4)

Electrical Data

Model No.	Volts	HZ 1 Phase	Amps	Watts	Heating Elements		NEMA
					Above Belt	Below Belt	
QCS2-1200B	208	60	15.9	3200	4	0	6-20P
	240	60	13.8	3200	4	0	6-20P
	220	50	15.0	3200	4	0	Not supplied with cord and plug
QCS3-1600B	208	60	17.8	3600	4	0	6-30P
	240	60	15.5	3600	4	0	6-30P
	220	50	16.9	3600	4	0	Not supplied with cord and plug

Typical Specifications

High performance Bagel Fast conveyor toasters are constructed of corrosion resistant stainless steel. Supplied with heavy-duty motor, drive chain and fast heat up quartz infrared heaters. A conveyor belt tension system is supplied for a smooth, quiet operation. Units are supplied with variable speed control, power saver and high limit switch. Extended conveyor belt, crumb tray, heated holding area and full width burn guards standard. Unit has a one-piece cover for easy access with 1" adjustable legs and a 4' cord. Units are listed with UL, CUL and are UL certified to NSF4. Patent number D459,140. Printed in the U.S.A.

Due to periodic changes in designs, methods, procedures, policies and regulations, the specifications contained in this sheet are subject to change without notice. While Star Manufacturing exercises good faith efforts to provide information that is accurate, we are not responsible for errors or omissions in information provided or conclusions reached as a result of using the specifications. By using the information provided, the user assumes all risks in connection with such use.

Star Manufacturing International, Inc. - 10 Sunnen Drive - P.O. Box 430129 - St. Louis, MO 63143-3800

Phone: (800) 264-7827 - FAX: (800) 264-6666 - www.star-mfg.com