



New **ULTRA-MAX® ELECTRIC GRIDDLES**
Models 724TA, 736TA, 748TA, 760TA & 772TA

Features/Benefits:

- ★ Ultra-Max griddles are designed for the highest volume food service operations and provide maximum performance and reliability.
- ★ Snap action thermostatic control adjusts from 150° to 450°F and provides accurate temperature control. Internal plate sensor accurately measures the temperature of the griddle plate 3/16" from the cooking surface for instant response to surface temperature change and fast recovery.
- ★ Available in 24", 36", 48", 60" and 72" widths to meet your space and volume requirements.
- ★ *NEW* longer lasting, heavy-duty metal knobs.
- ★ Highly polished 1" thick steel plate for superior heat distribution, fast recovery and energy efficient operation.
- ★ Custom designed 4350 watt heating element every 12" of cooking surface provides superior cooking performance.
- ★ Heavy-duty all-weld body construction with stainless steel front, side panels, bull nose and splash guard.
- ★ Heavy-duty design with stylishly curved, ergonomically advanced front panel providing easy access and viewing of controls.
- ★ Spatula wide 3-1/2" front grease trough and grease chute for easier cleaning.
- ★ Large 6 quart stainless steel grease drawer.
- ★ Extra-heavy-duty 4" adjustable legs to fit your countertop needs.
- ★ Floor model stands available for free standing unit. Optional casters available.
- ★ Cool-to-the-touch stainless steel bull nose front provides knob protection and comfortable work zone.



Model 736TA

Applications:

For breakfast, lunch or dinner, the Ultra-Max electric snap action griddles provide flexibility for a variety of menu items. Perfect for high volume operations.

Construction:

Ultra-Max griddles feature 1" thick highly polished steel griddle plate, 5" tapered stainless steel splash guard, 3-1/2" wide front access stainless steel grease trough, stainless steel 6 quart capacity grease drawer, and stainless steel front panels, side panels, and bull nose. Models 760TA and 772TA house two 6 quart grease drawers. Includes a 4350 watt element every 12" of width controlled by snap action electric thermostat. Griddles are equipped with a junction box at the rear for making electrical connections. Models 760TA and 772TA are equipped with 2 junction boxes. Heavy-duty 4" legs are included.

New **Warranty:**

Ultra-Max gas griddles are covered by Star's **THREE YEAR** parts and labor warranty.





New **ULTRA-MAX® ELECTRIC GRIDDLES** Models 724TA, 736TA, 748TA, 760TA & 772TA

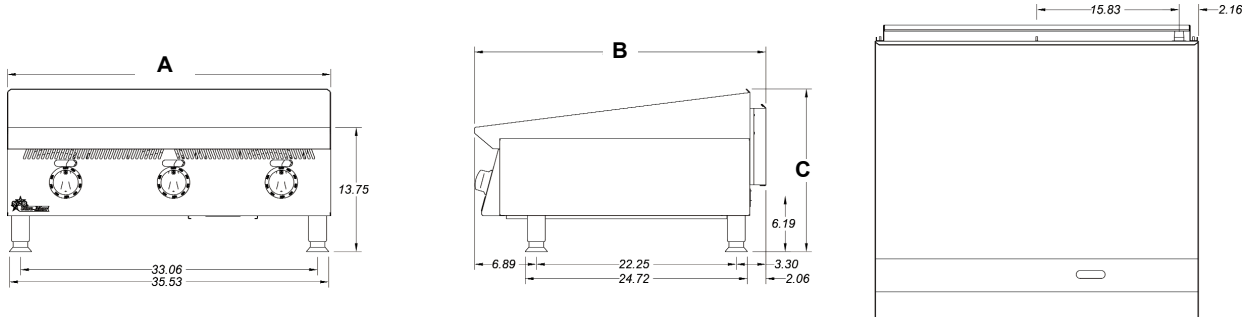

Specifications

Model No.	Dimensions			No. Controls	Watts	Grid Area	Plate Thickness	Approximate Weight	
	(A) Width Inches	(B) Depth Inches	(C) Height Inches					Installed	Shipping
724TA	24" (61 cm)	33-11/16" (85.5 cm)	18" (45.7 cm)	2	8,700	573 sq. in. (3,697sq cm)	1" (2.54 cm)	220 lbs. (99.7 kg)	290 lbs. (130.5kg)
736TA	36" (91.4 cm)	33-11/16" (85.5 cm)	18" (45.7 cm)	3	13,050	860 sq. in. (5,545 sq cm)	1" (2.54 cm)	330 lbs. (149.5 kg)	389 lbs. (175.1 kg)
748TA	48" (121.9cm)	33-11/16" (85.5 cm)	18" (45.7 cm)	4	17,400	1146 sq. in. (7,394 sq cm)	1" (2.54 cm)	440 lbs. (199.4 kg)	520 lbs. (234 kg)
760TA	60" (152.4 cm)	33-11/16" (85.5 cm)	18" (45.7 cm)	5	21,750	1433 sq. in. (9,242 sq cm)	1" (2.54 cm)	550 lbs. (249.2 kg)	656 lbs. (295.2 kg)
772TA	72" (182.9 cm)	33-11/16" (85.5 cm)	18" (45.7 cm)	6	26,100	1719 sq. in. (11,091 sq cm)	1" (2.54 cm)	660 lbs. (299.0 kg)	780 lbs. (351 kg)

Electrical Data

Model	Total KW	Voltage	AMPS-1 Phase	KW.-Load Phase			AMPS Per Phase		
				X-Y	X-Z	Y-Z	X	Y	Z
724TA	8.7	208	41.8	4.35	-	4.35	20.9	36.2	20.9
	8.7	240	36.3	4.35	-	4.35	18.1	31.3	18.1
736TA	13.05	208	62.7	4.35	4.35	4.35	36.2	36.2	36.2
	13.05	240	54.4	4.35	4.35	4.35	31.4	31.4	31.4
748TA	17.4	208	83.6	8.7	4.35	4.35	55.3	55.3	36.2
	17.4	240	72.5	8.7	4.35	4.35	48	48	31.4
760TA**	21.8	208	Dual Supply: 62.7 A. One Circuit & 41.8 A. Other Circuit	4.35	4.35	4.35	36.2	36.2	36.2
				4.35	-	4.35	20.9	36.2	20.9
760TA**	21.8	240	Dual Supply: 54.4 A. One Circuit & 36.3 A. Other Circuit	4.35	4.35	4.35	31.4	31.4	31.4
				4.35	-	4.35	18.1	31.3	18.1
772TA**	26.1	208	Dual Supply 62.7 EA. Circuit	4.35 ea.	4.35ea.	4.35 ea.	36.2 ea.	36.2 ea.	36.2 ea.
				4.35 ea.	4.35ea.	4.35 ea.	31.4 ea.	31.4 ea.	31.4 ea.

**INDICATES DUAL SUPPLY CIRCUITS

Typical Specifications

Gas griddles are constructed of stainless steel. Control knobs are protected by a stainless steel bull nose front. Griddle plate is a 1" (2.54 cm) thick highly polished steel plate with 5" (12.7 cm) high tapered wrap-around stainless steel splash guard. Unit has 3-1/2" (8.3 cm) wide front grease trough with grease chute and a 6 qt. (5.68 L) capacity stainless steel grease drawer. Models 760TA and 772TA house two each 6 quart (5.68 L) grease drawers. Units are equipped with a 4350 watt incoloy sheath element every 12" (330.48 cm) of griddle width and are controlled by a snap action thermostat. A terminal block is provided for making electrical connections. Models 760TA and 772TA are equipped with two electric connection boxes. Griddles are supplied with 4" (10.2 cm) high stainless steel legs that have a 1-5/8" (1.5 cm) adjustment. Units are approved for installation within 1" (2.54 cm) of side and rear wall combustible surfaces and are cULus Classified and UL classified to NSF Standard 4 Sanitation. Printed in the U.S.A.

Due to periodic changes in designs, methods, procedures, policies and regulations, the specifications contained in this sheet are subject to change without notice. While Star Manufacturing exercises good faith efforts to provide information that is accurate, we are not responsible for errors or omissions in information provided or conclusions reached as a result of using the specifications. By using the information provided, the user assumes all risks in connection with such use.

Star Manufacturing - 10 Sunnen Drive - P.O. Box 430129 - St. Louis, MO 63143-3800

Phone: (314) 678-6303 - FAX: (314) 781-5445 - www.star-mfg.com