



New **STAR-MAX® CHROME ELECTRIC GRIDDLES**

Models 524CHSF, 536CHSF & 548CHSF

Features/Benefits:

- ★ *NEW* Star-Max Chrome Griddles feature a 1" steel plate with a hard chrome surface providing superior cooking performance and even heat distribution.
- ★ *NEW* throttling thermostat inserted into the griddle plate 5/16" from the cooking surface, adjusts from 150° to 450°F providing quick response to surface temperature change.
- ★ Highly polished chrome surface reflects heat inward reducing radiant heat, lowering energy cost up to 30% and keeps the kitchen cooler.
- ★ *NEW* longer lasting, heavy-duty metal knobs.
- ★ Easy to clean chromium surface reduces labor costs up to 50% by sealing the surface and eliminating food build-up.
- ★ Cool-to-the-touch stainless steel bull nose front provides knob protection and comfortable work zone.
- ★ The non-porous chrome surface eliminates food taste transfer improving cooking performance.
- ★ Double wall construction and enclosed bottom helps reduce heat loss.
- ★ Available in 24", 36" and 48" widths to meet your space and volume requirements.
- ★ A 4000 watt heating element every 12" of cooking surface allows for fast recovery time.
- ★ Spatula wide 3-1/4" grease trough, grease chute for easy cleaning.
- ★ Large 4-1/2 quart stainless steel grease drawer.
- ★ Stainless steel, 4-1/2" high tapered splash guard provides maximum protection against grease and spills.
- ★ Heavy-duty 4" adjustable legs to match the height of other Star-Max equipment in your line.



Model 536CHSF

Applications:

Star-Max® Chrome Griddles are a perfect addition to any food service operation. Superior cooking performance, lower energy cost, and no food taste transfer will improve all of your menu items and keep your customers coming back for more!

Quality Construction:

Star-Max® Chrome Griddles are constructed with quality and durability in mind. The stainless steel front control panel, stainless steel bull nose front for knob protection, and nickel-plated die-cast legs offer years of easy maintenance and outstanding performance. Double wall construction allows installation within 1" of combustible surface. Griddles operate on 208 or 240 volts and are equipped with a junction box at the rear for making electrical connections.

New Warranty:

Star-Max® Chrome Griddles are covered by Star's **TWO YEAR** parts and labor warranty. In addition, the Chrome surface has a limited five year warranty.





Star Manufacturing

Star-Max® Chrome Electric Griddles

New

STAR-MAX® CHROME ELECTRIC GRIDDLES

Models 524CHSF, 536CHSF & 548CHSF

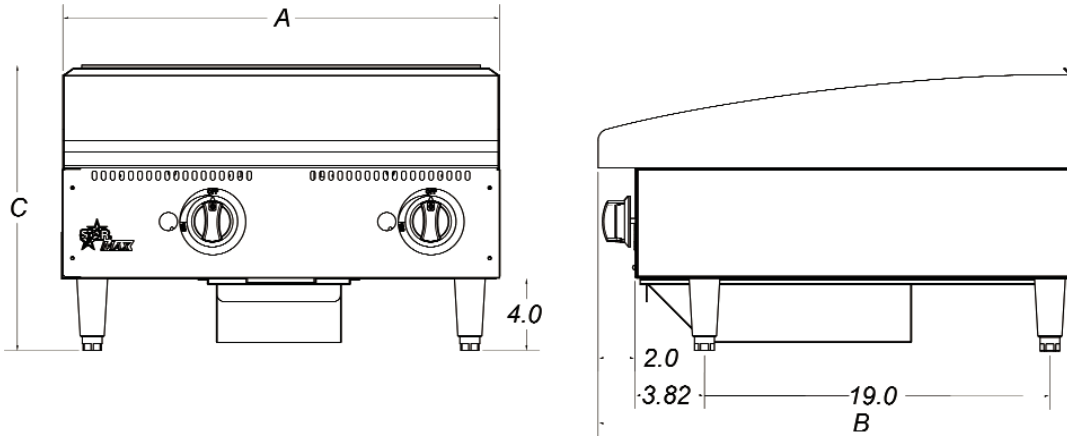

Specifications

Model No.	Dimensions			No. Controls	Watts	Grid Area	Plate Thickness Inches (cm)	Weight	
	(A) Width Inches (cm)	(B) Depth Inches (cm)	(C) Height Inches (cm)					Installed lbs. (kg)	Shipping lbs. (kg)
524CHSF	24 (61.0)	27-7/8 (70.8)	15-1/2 (39.4)	2	8000	498 sq. in. 3213.1 sq. cm	1 (2.5)	165 (74.8)	175 (79.4)
536CHSF	36 (91.4)	27-7/8 (70.8)	15-1/2 (39.4)	3	12,000	747 sq. in. 4819.6 sq. cm	1 (2.5)	247 (112.0)	262 (118.8)
548CHSF	48 (121.9)	27-7/8 (70.8)	15-1/2 (39.4)	4	16,000	996 sq. in. 6426.2 sq. cm	1 (2.5)	330 (149.7)	350 (158.8)

Electrical Data

Model No.	Rated Wattage		3 Phase Loading KW Per Phase						Nominal Amps Per Line Wire							
	208V	240V	208V			240V			208V-3PH			240V-3PH			208V 1PH	240V 1PH
			X-Y	Y-Z	X-Z	X-Y	Y-Z	X-Z	X	Y	Z	X	Y	Z		
524CHSF	6,008	8,000	3	3		4	4		14.4	25	14.4	16.7	28.9	16.7	28.9	33.3
536CHSF	9,012	12,000	3	3	3	4	4	4	25	25	25	28.9	28.9	28.9		
548CHSF	12,016	16,000	3	3	6	4	4	8	38.2	25	38.2	44.2	28.9	44.2	57.8	66.7

Typical Specifications

Electric griddles are constructed of a stainless steel front panel and double wall aluminized steel side panels. Griddle plate is 1" (2.54 cm) thick with a hard chrome plated surface. Unit has a 3-1/4" (8.3 cm) wide front grease trough with grease chute and a 4-1/2 qt. (4.3 L) stainless steel grease drawer and 4-1/2" tapered high splash guard. Unit is heated with a 4000 watt incoloy sheath type element every 12" (30.5 cm) of griddle width and is controlled with a snap-action thermostat embedded into the griddle plate. Thermostat knob is protected by a stainless steel bull nose front. Unit is supplied with 4" (10.2 cm) die cast nickel plated legs that have a 1-3/8" (3.5 cm) adjustment. A junction box is provided for making electrical connections. Units to be listed by Underwriters Laboratories and be UL Sanitation and UL Canada approved. Model 548CHSF is UL and UL Sanitation approved. Printed in U.S.A.

Due to periodic changes in designs, methods, procedures, policies and regulations, the specifications contained in this sheet are subject to change without notice. While Star Manufacturing exercises good faith efforts to provide information that is accurate, we are not responsible for errors or omissions in information provided or conclusions reached as a result of using the specifications. By using the information provided, the user assumes all risks in connection with such use.

Star Manufacturing - 10 Sunnen Drive - P.O. Box 430129 - St. Louis, MO 63143-3800
Phone: (314) 678-6303 - FAX: (314) 781-5445 - www.star-mfg.com