



Star Manufacturing
International Inc.

10 Sunnen Drive
P.O. Box 430129
St. Louis, MO 63143

Phone: (800) 264-7827
(314) 781-5353 (Int'l)
FAX: (800) 264-6666
(314) 781-4344 (Int'l)
www.star-mfg.com

Star-Max™ Electric Hot Plates

Model 502A
Model 502FA - French Style

Versatility plus Value with Star-Max Electric Hot Plates from Star...

Features/Benefits:

Model 502A Coil Type

- ★ Convenient lift out drip pan for ease of cleaning.
- ★ Incoloy sheath tubular elements plug in for easy removal and cleaning
- ★ Independent controls for temperature control.

Model 502FA Solid Top (French Style)

- ★ Sealed cast iron type elements provide a solid flat surface for faster, more even heating.
- ★ Solid top prevents spills from entering unit and makes clean-up and maintenance fast and easy.
- ★ Independent controls for temperature control.

Applications:

Need to keep product warm? Star has the answer.

Construction:

The model 502A and 502FA Hot Plates are constructed with quality in mind. Both models feature aluminized steel body and drip pan with stainless steel top and a stainless steel bullnose front to protect the control knobs. The attractive black polycarbonate trim matches other Star-Max™ Griddles, Fryers, and Char-Broilers. The hot plates operate on 208/240 volts and are equipped with a junction box at the rear for making electrical connections. Both units feature infinite controls with 2 pilot lights.

Warranty:

Star-Max™ Electric Hot Plates are covered by Star's one year parts and labor warranty.

Model 502A



Model 502FA





Star Manufacturing
International Inc.

10 Sunnen Drive
P.O. Box 430129
St. Louis, MO 63143

Phone: (800) 264-7827
(314) 781-5353 (Int'l)
FAX: (800) 264-6666
(314) 781-4344 (Int'l)
www.star-mfg.com

Star-Max™
Electric
Hot Plates

Model 502A
Model 502FA- French Style

Versatility plus Value with Star-Max Electric Hot Plates from Star...

Top of Model 502FA

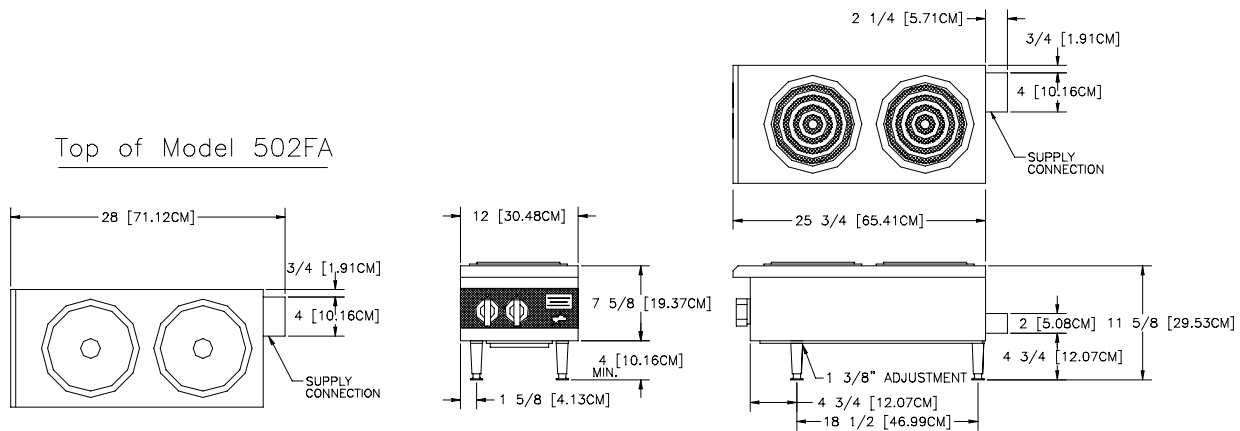

Specifications

Model No.	Dimensions			Cooking Surface Height	Approximate Weight	
	Height	Width	Depth		Installed	Shipping
502A	11-5/8" (29.5 cm)	12" (30.5 cm)	28" (71.1 cm)	11-5/8" (29.5 cm)	30 lbs. (13.6 kg)	40 lbs. (18.1 kg)
502FA	11-5/8" (29.5 cm)	12" (30.5 cm)	28" (71.1 cm)	11-5/8" (29.5 cm)	35 lbs. (15.9 kg)	45 lbs. (20.4 kg)

4" (10.16 cm) legs with 1-3/8" (3.5 cm) adjustment

Electrical Data

Model No.	Rated Wattage		Nominal Amps - Single Phase	
	208V	240V	208V	240V
502A	3150	4200	15.1	17.5
502FA	3900	5200	18.8	21.6

Typical Specifications

Electric hot plates are constructed of aluminized steel with stainless top and front and feature black polycarbonate trim. Units are equipped with infinite controls, 2 pilot lights, and are available with incoloy sheath tubular elements or sealed cast iron elements. Hot plates have a junction box at the rear of the unit and operate on 208/240 volts. Units carry the approval of Underwriters' Laboratories, NSF listed and CSA approved. Printed in the U.S.A.