



HOT FOOD MERCHANDISERS

Model 12MC and 15MC

Features/Benefits:

- ★ Star's Hot Food Merchandisers are perfect for merchandising sandwiches, burritos, cookies and a variety of product for your foodservice application.
- ★ Adjustable infinite temperature control allows you to adjust your day part menu up to 180°F depending on menu requirements.
- ★ Forced air system circulates air throughout the cabinet keeping your menu items at proper serving temperature.
- ★ 12" model has two perforated shelves (9-3/4"W x 10-1/4"D) easily adjustable to flat or angled positions for displaying a variety of day part foods.
- ★ 15" model has three perforated shelves (12-1/4"W x 12-3/4"D) easily adjustable to flat or angled positions for displaying a variety of day part foods.
- ★ A 100 watt interior incandescent light "showcases" products and builds impulse sales.
- ★ Attractive colorful "Fresh & Fast" graphics enhance your grab and go items for the time starved consumer.
- ★ Thermometer, located on interior side of the unit, allows for easy reading of cabinet temperature.
- ★ Bottom control panel houses ON/OFF switch and temperature control knob for precise temperature control.



Model 12MC

Applications:

Star's Hot Food Merchandiser is the best way to serve your day part menu items. Holds and serves products such as sandwiches, burritos, cookies and other foods in convenience stores, snack bars, recreational facilities, fun centers, theme parks, restaurants, taverns or wherever you might want to serve the "eat on the go" consumer.

Quality Construction:

Star's Hot Food Merchandiser is constructed with heavy-duty aluminum corner posts and a 3/16" thick glass panels. Unit incorporates a glass door with full length handle to stand up to commercial use. Unit is supplied with a 100 watt incandescent light. Equipped with a 400 or 500 watt heating element (depending on unit) and infinite temperature control. A 6' lead in cord and NEMA 5-15P come standard with unit.



Model 15MC

Warranty:

Hot Food Merchandisers are covered by Star's one year parts and labor warranty.





Star Manufacturing International, Inc

Hot Food Merchandisers

HOT FOOD MERCHANDISERS Model 12MC and 15MC

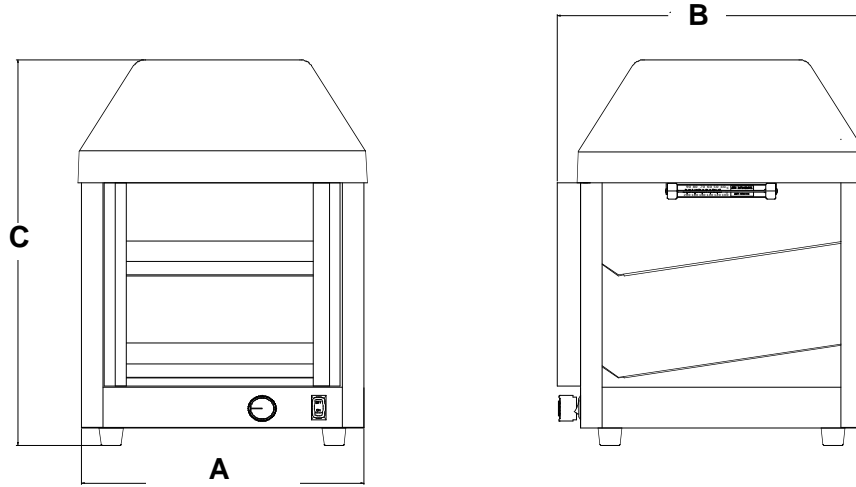

Performance Data

Model No.	Capacity	Door Opening (I.D.)
12MC	12 - 4" diameter Cookies	10"
12MCPT	14 - 7 oz. Breakfast Burritos	
15MC	27 - 4" diameter Cookies	12-1/2"
15MCPT	21 - 7 oz. Breakfast Burritos	

Specifications

Model No.	Dimensions			Approximate Weight	
	(A) Width Inches (cm)	(B) Depth Inches (cm)	(C) Height Inches (cm)	Installed lbs. (kg)	Shipping lbs. (kg)
12MC	12-1/2	13-5/8	18-7/8	22	31
12MCPT	(31.8)	(34.7)	(47.9)	(10.0)	(14.0)
15MC	15	16-7/8	24-7/8	38	43
15MCPT	(38.1)	(42.9)	(63.2)	(17.3)	(19.4)

Electrical Data

Model No.	Volts	Watts	NEMA Plug
12MC & 12MCPT	120V 230V	550 550	5-15P CEE7-7
15MC & 15MCPT	120V 230V	650 650	5-15P CEE7-7

Typical Specifications

Star's Hot Food Merchandisers are constructed with heavy-duty aluminum corner posts. Glass panel body construction with a 3/16" thick glass door with one-piece full length hinge and handle to stand up to commercial use. Forced air system circulates air throughout the cabinet. Outfitted with a 400 or 500 watt (respectively) element and infinite temperature control. Unit with 120V come with a 100 watt incandescent light and a 6' lead in cord with NEMA 5-15P, 230V units come with a CEE7-7 plug. Units are approved by CUL, UL, and UL Sanitation to NSF Standard 4. Printed in the U.S.A.

Due to periodic changes in designs, methods, procedures, policies and regulations, the specifications contained in this sheet are subject to change without notice. While Star Manufacturing exercises good faith efforts to provide information that is accurate, we are not responsible for errors or omissions in information provided or conclusions reached as a result of using the specifications. By using the information provided, the user assumes all risks in connection with such use.

Star Manufacturing International Inc. - 10 Sunnen Drive - P.O. Box 430129 - St. Louis, MO 63143-3800

Phone: (800) 264-7827 - FAX: (800) 264-6666 - www.star-mfg.com