

Non-Refrigerated Self-Service Pastry Case

- PC3982 41"L x 39"D x 83 1/4"H
- PC5682 58"L x 39"D x 83 1/4"H
- PC7482 76"L x 39"D x 83 1/4"H



MODEL SHOWN: PC5682

NOTE: SHOWN W/CUTAWAY END PANEL OPTION. TRAYS NOT PROVIDED

STANDARD FEATURES

- Electrical connect-12" straight blade power cord
- Warranty-One year parts & labor warranty
- Shelves-Shelving removable and adjustable on 1" centers
- Trays-PC3982 holds (10) 18" x 26" trays
- Trays-PC5682 holds (15) 18" x 26" trays
- Trays-PC7482 holds (20) 18" x 26" trays
- Upper display-Angled mirror in upper display
- Upper front-Glass swinging front doors

	STANDARD SPECIFICATION	OPTION(s)
BASE STYLE	<input type="checkbox"/> Straight base w/o front storage	<input type="checkbox"/> Angled base w/ front storage & waste bin <input type="checkbox"/> Straight base w/ front storage & waste bin
REAR STORAGE	<input type="checkbox"/> Non-refrigerated rear storage (w/o doors)	<input type="checkbox"/> Non refrigerated rear storage (w/doors)
INTERIOR COLOR	<input type="checkbox"/> White interior	<input type="checkbox"/> Black interior
EXTERIOR COLOR	<input type="checkbox"/> Painted exterior (specify color)	<input type="checkbox"/> Laminated exterior (Wilsonart/Formica non-premium) <input type="checkbox"/> Laminated exterior (Wilsonart/Formica premium)
HEADER STYLE	<input type="checkbox"/> Curved header	<input type="checkbox"/> Square header
END PANEL LEFT	<input type="checkbox"/> Full end panel w/mirror interior	<input type="checkbox"/> Cutaway end panel <input type="checkbox"/> Case to case joiner kit <input type="checkbox"/> No end panel (for same case to case connections)
END PANEL RIGHT	<input type="checkbox"/> Full end panel w/mirror interior	<input type="checkbox"/> Cutaway end panel <input type="checkbox"/> Case to case joiner kit <input type="checkbox"/> No end panel (for same case to case connections)
UPPER REAR	<input type="checkbox"/> Solid back panel	<input type="checkbox"/> Mirror sliding doors <input type="checkbox"/> Solid back panel, mirror <input type="checkbox"/> Reflective glass rear sliding doors w/o lock
PRICE TAG MOULDING	<input type="checkbox"/> None	<input type="checkbox"/> Price tag moulding
SHELVING	<input type="checkbox"/> Tray support, lighted shelves	<input type="checkbox"/> Wire rack(s), lighted (T-8)
BUMPER	<input type="checkbox"/> None	<input type="checkbox"/> 1" bumper on front & ends (specify color) <input type="checkbox"/> 1" bumper on front (specify color) <input type="checkbox"/> 1" bumper on front & left end (specify color) <input type="checkbox"/> 1" bumper on front & right end (specify color)

PRODUCT SPECIFICATIONS

Intended Use of Display Area: Packaged non-refrigerated products

Integrated Product Temperature (IPT): Ambient°F

Intended Environment: Designed to operate in ambient conditions of 75°F / 55% relative humidity.

PLAN VIEW

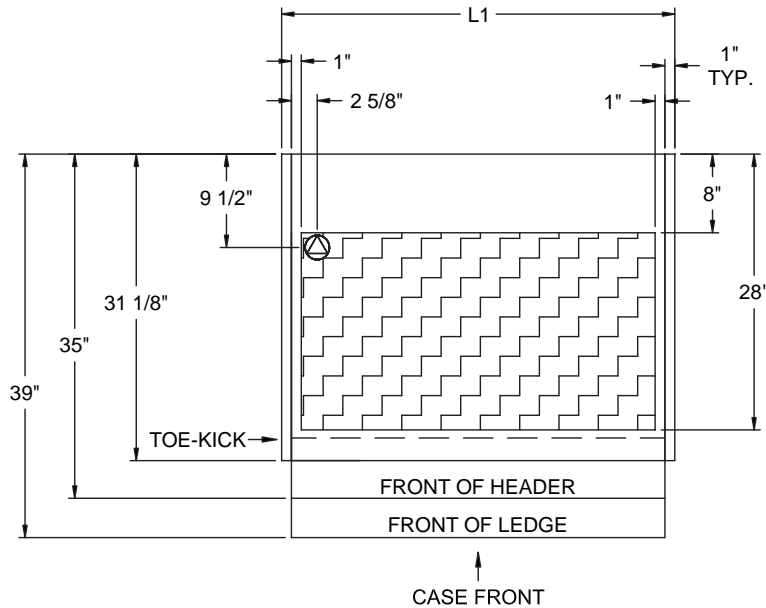

SIDE VIEW

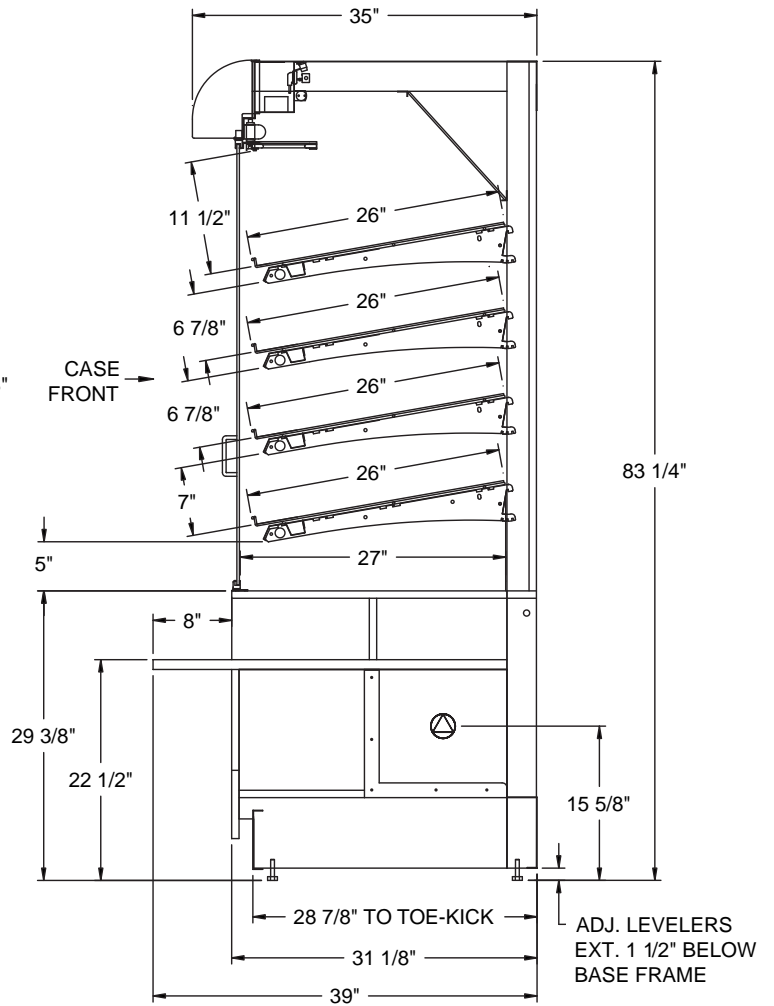

NOTE: ALL DIMENSIONS APPROXIMATE

- ⊗ ELECTRICAL JUNCTION BOX (SUPPLIED WITH 6" LEADS OR POWER CORD)
- ⊙ LOCATION OF CONDENSATE DRAIN TUBE (SUPPLIED WITH 3/4" OR 1 1/2" PVC DRAIN TUBE)
- ▨ PREFERRED LOCATION FOR SERVICE ENTRY
- ⊕ REFRIGERANT LINE CONNECTION

Model	Self-Contained Refrigeration/Dry					Remote Refrigeration w/Leads			Ship Wt	Frt Cls
	L1*	L2*	Volts++	Amps	NEMA Plug	Volts++	Amps***	BTUH		
PC3982	41	N/A	120/1/60	1.43	NEMA 5-15 P	N/A	N/A	N/A	1150	150
PC5682	58	N/A	120/1/60	1.84	NEMA 5-15 P	N/A	N/A	N/A	1150	150
PC7482	76	N/A	120/1/60	2.12	NEMA 5-15 P	N/A	N/A	N/A	1150	150

++ Operating range for 120 volt rating is 110-120 volts; operating range for 220 volt rating is 208-230 volts.

** Requires 3 wires + ground

*** Does not include electric defrost on freezer models

REGULATORY APPROVALS

- ETL Listed Certified to CAN/CSA 22.2
- ETL Listed Conforms to UL 65
- ETL Sanitation Conforms to NSF 2

Important Note:

40" Minimum door entry clearance required (Without shipping skid).