

NOTE:

1. ALL VISIBLE WELDS TO BE GROUND SMOOTH AND POLISHED TO A MATCHING FINISH.
2. ALL NON-VISIBLE WELDS TO BE GROUND SMOOTH AND PAINTED WITH F.I. APPROVED PAINT
3. ALL EDGES TO BE SMOOTH & FREE FROM BURRS
4. ALL FABRICATION TECHNIQUES AND COMPONENTS TO BE APPROVED BY F.I. PRIOR TO FABRICATION

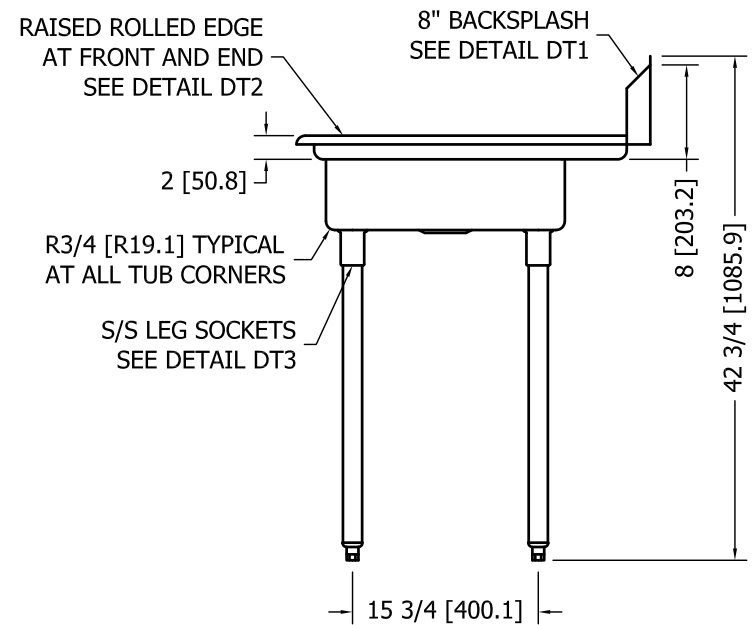
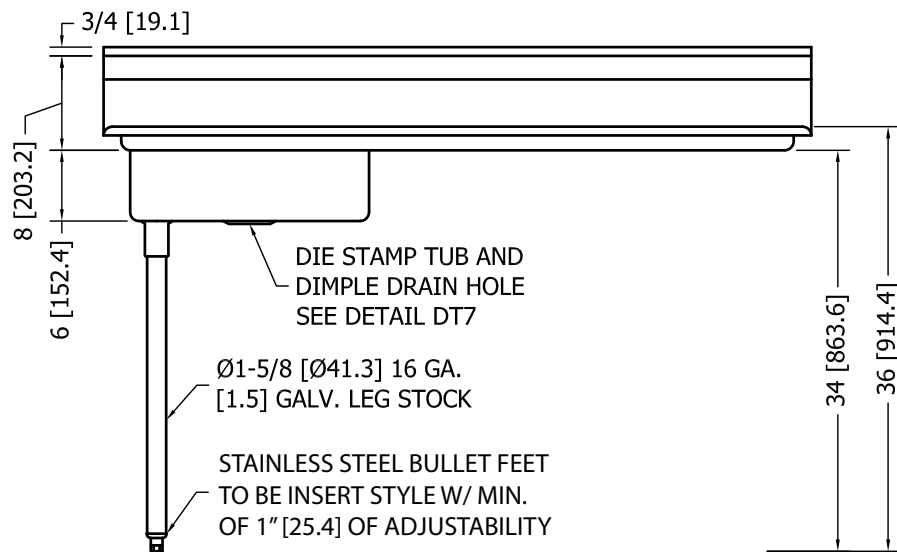

UDT-60-L

DRAWN BY: TCP

DATE: 04/12/06

REVISED: \_/\_/\_

\\DRAWINGS\PRODUCT\DISHTABLES\UDT\UDT60L.DWG

**NOTE:**

1. ALL VISIBLE WELDS TO BE GROUND SMOOTH AND POLISHED TO A MATCHING FINISH.
2. ALL NON-VISIBLE WELDS TO BE GROUND SMOOTH AND PAINTED WITH F.I. APPROVED PAINT
3. ALL EDGES TO BE SMOOTH & FREE FROM BURRS
4. ALL FABRICATION TECHNIQUES AND COMPONENTS TO BE APPROVED BY F.I. PRIOR TO FABRICATION

16 GA. [1.5] 304 #4  
S/S CONSTRUCTION

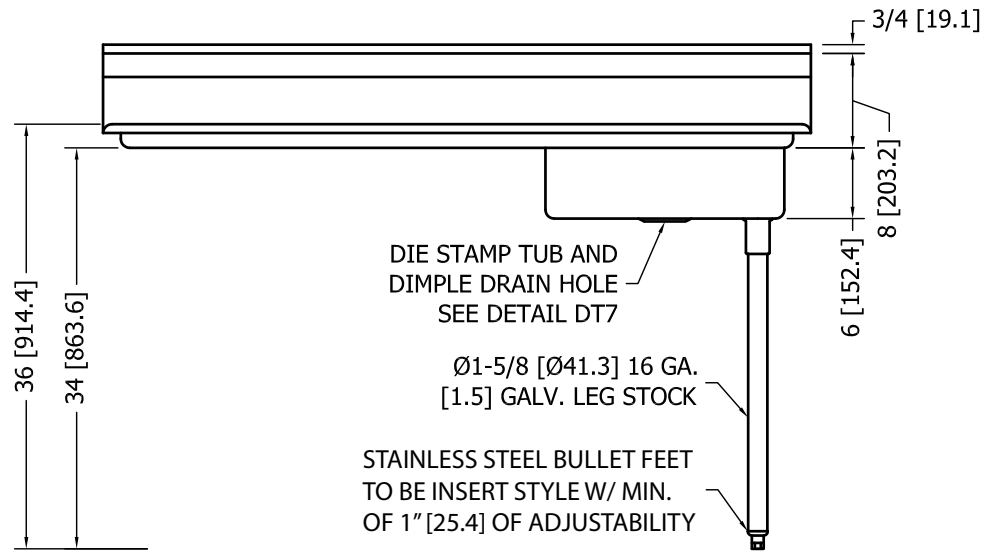
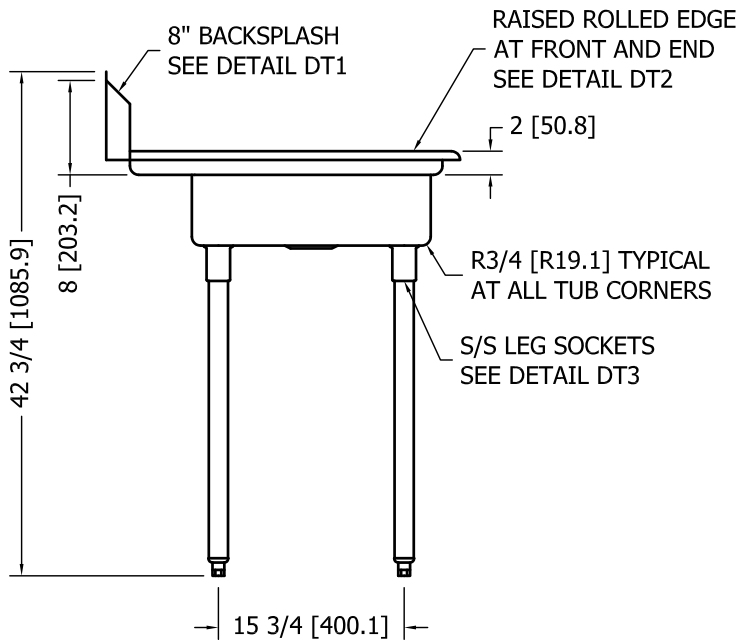
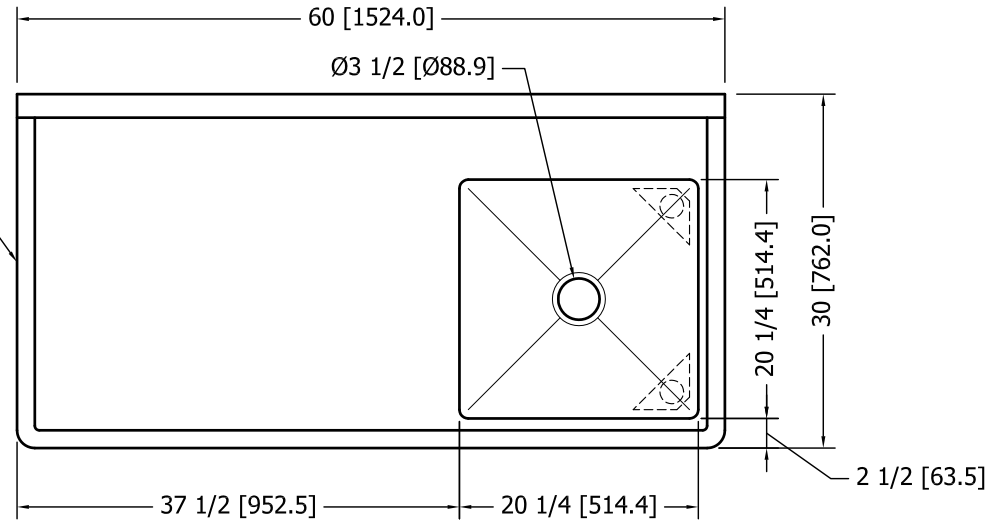

**UDT-60-R**

DRAWN BY: TCP

DATE: 04/12/06

REVISED: \_/\_/\_