



Profit from the Eagle Advantage®

# Specification Sheet

## Short Form Specifications

Eagle 1800 Series Modular Angle Fillers, model \_\_\_\_\_. Top, front, and backsplash to be heavy gauge type 304 stainless steel, with galvanized sides. (Front /Rear) filler available in 30°, 45°, 60°, and 90° angles. All units have predrilled mounting holes.

Eagle 1800 Series Modular Corner Drainboards, model \_\_\_\_\_. Top, front, and backsplash to be heavy gauge type 304 stainless steel with galvanized sides, and embossed work surface. #MRC-18 includes one 1 5/8" O.D. galvanized tubular leg with adjustable bullet foot. Both units have predrilled mounting holes.



front angle filler



rear angle filler



front corner drainboard



rear corner drainboard

Item No.:	_____
Project No.:	_____
S.I.S. No.:	_____

## 1800 Series Modular Angle Fillers and Corner Drainboards

### MODELS:

- |                                  |                                  |                                 |
|----------------------------------|----------------------------------|---------------------------------|
| <input type="checkbox"/> MF30-18 | <input type="checkbox"/> MF60-18 | <input type="checkbox"/> MRC-18 |
| <input type="checkbox"/> MR30-18 | <input type="checkbox"/> MR60-18 | <input type="checkbox"/> MFC-18 |
| <input type="checkbox"/> MF45-18 | <input type="checkbox"/> MF90-18 |                                 |
| <input type="checkbox"/> MR45-18 | <input type="checkbox"/> MR90-18 |                                 |

### Modular Angle Fillers

- Stainless steel front and top.
- Galvanized steel sides.
- Joins 1800 Series units by the corners.
- Front and rear fillers available in angles of 30°, 45°, 60° and 90°.
- All units have predrilled mounting holes.

### Modular Corner Drainboards

- All-welded construction.
- Galvanized panels attach to other equipment, stainless steel outer panels remain visible.
- Joins 1800 Series units by the corners.
- #MRC-18 provided with one 1 5/8" (41mm)-diameter leg.
- Both units have predrilled mounting holes.

### EAGLE GROUP

100 Industrial Boulevard, Clayton, DE 19938-8903 USA  
 Phone: 302-653-3000 • 800-441-8440 • Fax: 302-653-2065  
[www.eaglegrp.com](http://www.eaglegrp.com)  
[www.eaglemhc.com](http://www.eaglemhc.com)

For custom configuration or fabrication needs, contact our SpecFAB® Division.  
 Phone: 302-653-3000 • Fax: 302-653-2065 • e-mail: [quotes@eaglegrp.com](mailto:quotes@eaglegrp.com)



EG40.57 Rev. 10/24

Spec sheets available for viewing, printing or downloading from our online literature library at our websites

Eagle Foodservice Equipment, Eagle MHC, and SpecFAB® are divisions of Eagle Group. ©2024 by the Eagle Group



Item No.: \_\_\_\_\_  
 Project No.: \_\_\_\_\_  
 S.I.S. No.: \_\_\_\_\_

### 1800 Series Modular Angle Fillers

#### 30° Angle Fillers

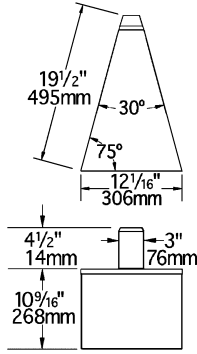

#MF30-18 Front Filler

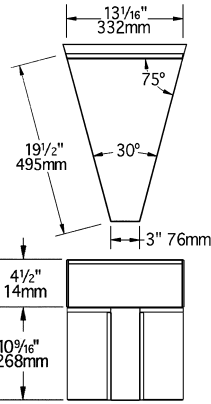

#MR30-18 Rear Filler

FRONT model #	REAR model #	weight lbs.	weight kg
MF30-18	MR30-18	15	6.8

#### 45° Angle Fillers

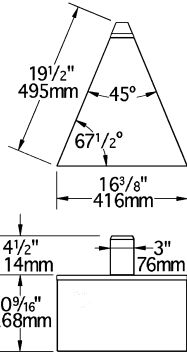

#MF45-18 Front Filler

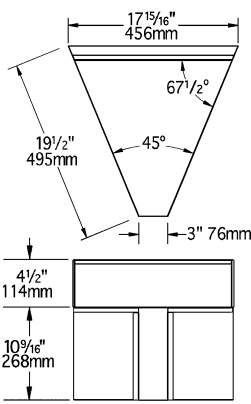

#MR45-18 Rear Filler

FRONT model #	REAR model #	weight lbs.	weight kg
MF45-18	MR45-18	16	7.3

#### 60° Angle Fillers

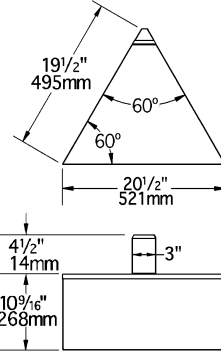

#MF60-18 Front Filler

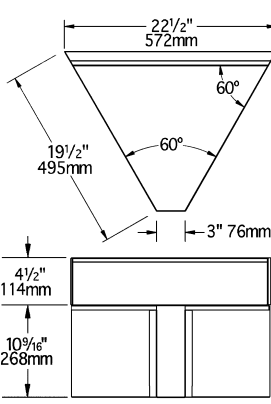

#MR60-18 Rear Filler

FRONT model #	REAR model #	weight lbs.	weight kg
MF60-18	MR60-18	19	8.6

#### 90° Angle Fillers

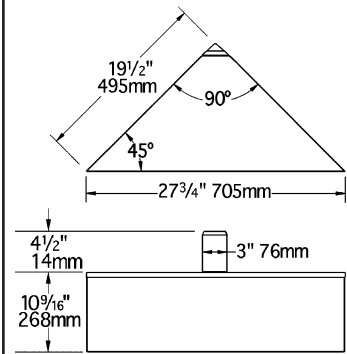

#MF90-18 Front Filler

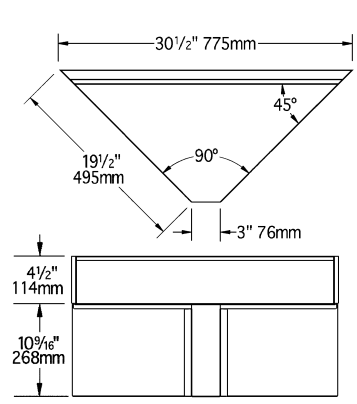

#MR90-18 Rear Filler

FRONT model #	REAR model #	weight lbs.	weight kg
MF90-18	MR90-18	21	9.5

### Corner Drainboards – 1800 Series

FRONT model #	REAR model #	weight lbs.	weight kg
MFC-18	MRC-18	37	16.8

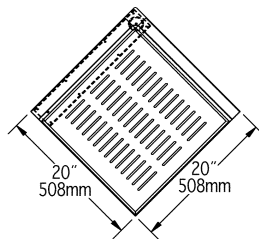

#MRC-18 Rear Corner Drainboard

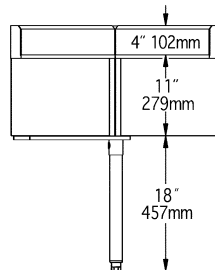

#MFC-18 Front Corner Drainboard

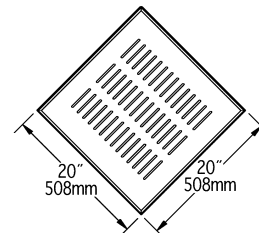

**EAGLE GROUP**

100 Industrial Boulevard, Clayton, DE 19938-8903 USA  
 Phone: 302-653-3000 or 800-441-8440 • Fax: 302-653-2065  
 www.eaglegrp.com • www.eaglehmc.com

Printed in U.S.A.  
 ©2024 by Eagle Group

Rev. 10/24

Spec sheets available for viewing, printing or downloading from our online literature library at our websites

Although every attempt has been made to ensure the accuracy of the information provided, we cannot be held responsible for typographical or printing errors. Information and specifications are subject to change without notice. Please confirm at time of order.