

Foodservice Equipment • Material Handling, Healthcare & Cleanroom Equipment • Retail Display

Item #: _____ Qty.: _____
 Model #: _____ Project #: _____

Gas Water Bath Steam Tables

Optional Accessories	Model #	Qty.
Adj. Undershelf		
Tray Slide/Shelf		
Rolltop Cover		
Serving shelf		
Top adapters		
Food pans/inserts		



new exclusive design



- ◆ top and water pan are easily removable for cleaning or replacement
- ◆ all units are furnished with a straight flow tubular gas burner and pressure regulator as standard equipment
- ◆ AWTP models are provided with safety pilots and automatic shut-off features
- ◆ adjustable undershelf available
- ◆ top openings are sized to accept 12" x 20" food pans
- ◆ all units are furnished with a maple cutting board and stainless steel dish shelf

Spec sheets available for viewing, printing or downloading from our online literature library at www.eaglegrp.com

For custom configuration or fabrication needs, contact our **SpecFAB Division**.
 Phone: (302) 653-3000. FAX: (302) 653-3091.
 E-mail: specfab@eaglegrp.com



Gas Water Bath Steam Tables

design & construction features

construction —Table body and top constructed of highly polished 20 gauge 430 series stainless steel. Top has openings sized to accommodate 12" x 20" food pans. Laminated, hardwood cutting board 8" wide and 1 1/4" thick is mounted on stainless steel brackets located on control side of unit. Cutting board and stainless steel dish shelf are standard on all models. Legs are 1 5/8" O.D. galvanized tubing fitted with adjustable, non-marking plastic feet. Undershelf constructed of galvanized steel. Stainless steel adjustable undershelf and 16/304 stainless steel legs are available as options.

water pan — 20 gauge 304 stainless steel all seamless construction complete with 1 1/2" diameter brass drain.

burner assembly — Constructed of aluminized steel with straight flow energy saving design for quick start up. 15,000 BTU burner — 2- and 3-opening models, 30,000 BTU burner — 4-, 5-, and 8-opening models. 1/2" N.P.T. pipe connection is on right side. Available in LP gas.

optional safety pilot — AGA design certified complete with high performance cast aluminum automatic shut-off valve and pressure regulator.

Dimension A	
2 well	8" (203 mm)
3 well	15 1/2" (294 mm)
4 well	15 1/2" (294 mm)
5 well	23" (584 mm)

***note:** model #AWTP(4)-NG-1 is provided with (2) 12" x 20", (4) round and (2) 6 1/2" round openings

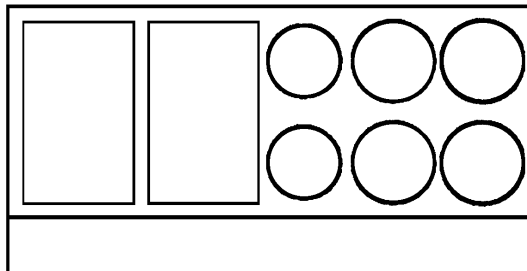
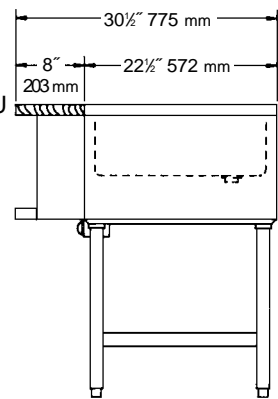

MODELS: AWT4-NG-1
AWTP4-NG-1

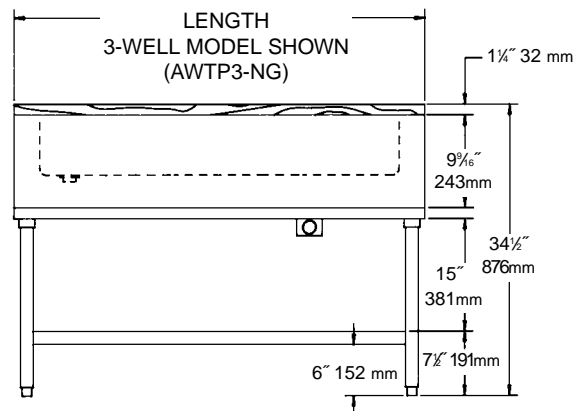
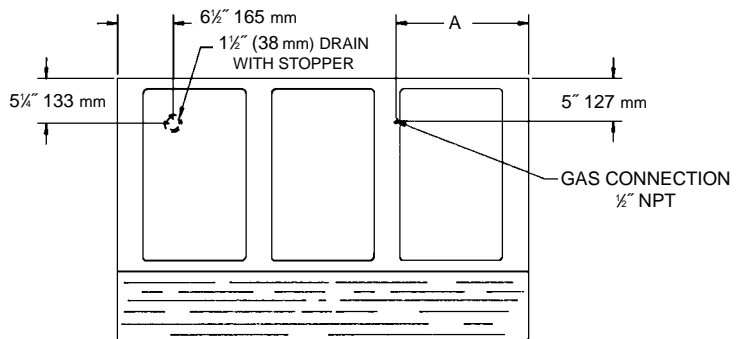

description	model #	shipping lbs.	kg.
2 top openings — 33" long	AWT2-NG	94	42.6
as above, with safety pilots	AWTP2-NG	96	43.5
3 top openings — 48" long	AWT3-NG	125	56.7
as above, with safety pilots	AWTP3-NG	130	59.0
4 top openings — 63 1/2" long	AWT4-NG	146	66.2
as above, with safety pilots	AWTP4-NG	151	68.4
8 top openings — 63 1/2" long	AWT4-NG-1*	183	83.0
as above, with safety pilots	AWTP4-NG-1*	189	85.7
5 top openings — 79" long	AWT5-NG	146	66.2
as above, with safety pilots	AWTP5-NG	151	68.4

To order stainless steel legs and undershelf, add letter **S** to front of model # — replace NG in model # with **LP** if LP gas is desired.

Add Suffix "AU" to model number to indicate adjustable undershelf. Add Flex-Master overshelf

note: consult spec sheet 30.20 for accessories