



Euro Series Hot Food Merchandisers

ES 1-1P, ES 2-2P, ES 3-3P

***The ultimate in countertop
hot food merchandising!
Up to the minute styling with
traditional Merco efficiency
and quality.***



*Model ES-3-3P
Shown with Standard Pan Racks
(pans optional)*

Standard Features

Merco's patented EZ-Insert type heat tubes in top and middle shelves with insulated heat cable base unit – Individual, infinitely adjustable heat controls for all three levels – Pilot lights – Bright incandescent illumination in top and middle shelves with on/off switch – Stainless steel work surfaces – Adjustable 4-inch NSF legs – Removable, sliding glass doors on cook side – One-piece curved front glass – Pan racks (pans optional) – 6-foot cordset.

Merco Euro-Series Hot Food Merchandisers feature stylish good looks combined with Merco's traditional high quality construction and efficiency for the ultimate in countertop hot food merchandising. The unique cantilevered two-level design holds and displays a wide variety of product. The infinitely adjustable heat controls let you dial-in the perfect temperature to keep any food at its peak of flavor without continued cooking or excessive drying. Removable, sliding glass doors on cook-side for easy access. Pan racks are standard and a 6-foot cordset is provided for easy plug-in installation. The dramatic curved front glass and bright incandescent illumination displays food at its best to increase sales.

Electrical Requirements

All models are available in 120, 120/208 pr 120/240 volt, single phase AC only. Model ES 1-1P available in 120 volt only.



1111 North Hadley Road
P.O. Box 1229
Fort Wayne, IN 46801-1229
Phone: (219) 459-8200 / Fax: (219) 459-8240
Toll Free 800 547-2513



Printed in USA,
Designs and specifications are subject to change without notice
© 2001 Merco Products, Inc., All Rights Reserved

Euro Series Hot Food Merchandisers

ES 1-1P, ES 2-2P, ES 3-3P

Dimensions (inches/cm)

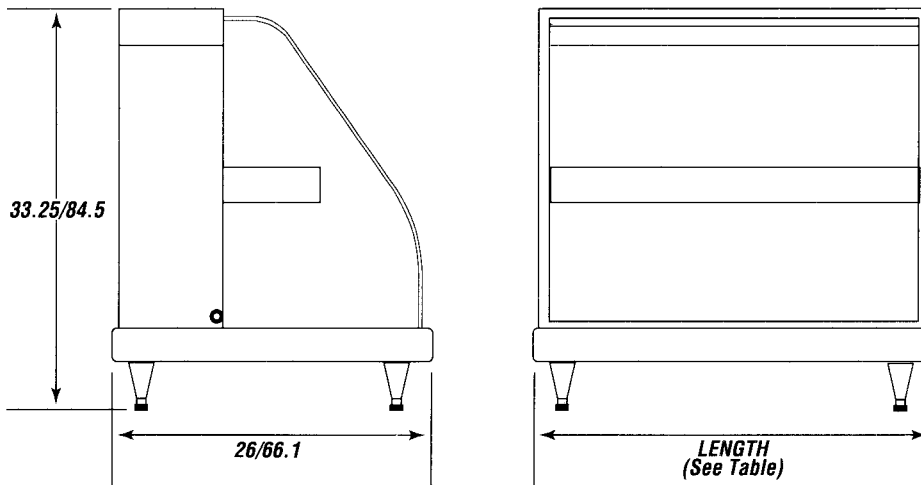

Specifications (Standard models)

MODEL #	VOLTAGE/AMPS			WATTS	LENGTH inches/cm	NET WT.* lbs/kg	SHIP WT.* lbs/kg	SHIP VOL.* cu ft/cu m
	120V	120/208V	120/240V					
ES 1-1P	12.2	N/A	N/A	1460	16.5/41.9	95/43.1	110/49.9	10.2/0.29
ES 2-2P	15.1	8.7	7.5	1810	33/83.8	130/59.0	175/79.5	16.5/0.46
ES 3-3P	19.1	11.0	9.5	2290	44/111.8	170/77.2	215/97.6	22/0.62

*Measurements are approximate

Options & Accessories

Mirror-back sliding glass doors on cook-side

Full- and half-size stainless steel pans

Full- and half-size wire trivets

Bid Specifications for Euro-Series Hot Food Merchandisers

The Euro-Series Hot Food Merchandiser shall be a Merco Model number _____, rated at _____ watts, _____ volts, single phase AC.

Standard equipment shall include heat cable base, infinitely adjustable heat controls for all levels, pilot lights, bright incandescent illumination with on/off switch, removable sliding glass doors, adjustable 4" NSF legs, pan racks, 6-foot cordset. Optional accessories shall include mirror-back doors, full and 1/2 size stainless steel pans and wire trivets.

 **Merco Savory**

Enodis

1111 North Hadley Road

P.O. Box 1229

Fort Wayne, IN 46801-1229

Phone: (219) 459-8200 / Fax: (219) 459-8240

Toll Free 800 547-2513

Merco Guarantee

Ninety (90) day warranty on labor, one (1) year on parts from date of purchase. Three (3) year warranty from date of purchase on heat tubes (excluding light bulbs).