



2-Tier Hot Food Merchandisers

1220-2-3P, 1220-3-4P, 1220-4-5P, 1220-5-6P

Holds more food longer in less space! Ideal for cafeterias, delicatessens, markets, convenience stores, etc.



Model 1220-2-3P Shown with Standard Pan Racks (pans are optional)

Standard Features

- Merco's patented EZ-Insert® heat tubes in upper and middle levels
- Insulated heat cable in bottom level
- Individual, infinitely adjustable heat controls with pilot lights for each level
- Bright incandescent illumination with on/off switch
- Stainless steel and aluminum construction
- Adjustable 4-inch NSF legs
- Removable sliding glass doors on cook side
- Pan racks (pans optional)
- 6-foot cordset

Merco 2-Tier Hot Food Merchandisers allow you to offer a larger selection of food while using less of your valuable counter space. Heavy-duty stainless steel and aluminum alloy construction for long life and easy cleaning. Merco's patented EZ-Insert heat tubes in the upper levels are matched with the insulated heat cable in the bottom level to provide thorough, even heating without continued cooking or drying. Individual, infinitely adjustable heat controls for each level let you "dial-in" the precise temperature to keep any food at its peak flavor. Bright incandescent illumination is included in both upper and middle levels to enhance the appearance of prepared food. Removable sliding glass doors on cook side for easy access and pop-out glass panels are provided on front and end panels. Pan racks are standard equipment (pans optional). A 6-foot cordset is provided for easy installation.

Four standard models are available to match any foodservice requirement. Available options include self-service, slant and/or sled legs, heat shields and sign holders.

Electrical Requirements

All models available in 120, 120/208 or 120/240 VAC, single phase only (except 1220-5-6P not available in 120 VAC).



1111 North Hadley Road
P.O. Box 1229
Fort Wayne, IN 46801-1229
Phone: (219) 459-8200 / Fax: (219) 459-8240
Toll Free 800 547-2513



Printed in USA,
Designs and specifications are subject to change without notice
© 2001 Merco Products, Inc., All Rights Reserved

2-Tier Hot Food Merchandisers

1220-2-3P, 1220-3-4P, 1220-4-5P, 1220-5-6P

Dimensions (inches/cm)

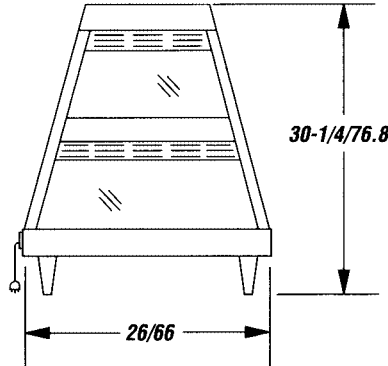
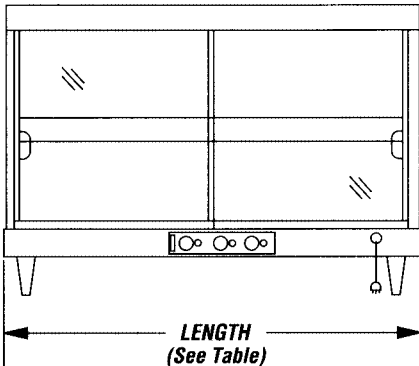

Specifications (Standard models)

MODEL #	VOLTAGE/AMPS			WATTS	LENGTH inches/cm	NET WT.* lbs/kg	SHIP WT.* lbs/kg	SHIP VOL.* cu ft/cu m
	120V	120/208V	120/240V					
1220-2-3P	13.2	7.6	6.6	1500	33/83.8	79/35.9	146/66.3	19/0.54
1220-3-4P	15.1	9.6	8.3	1820	44/111.8	118/53.6	190/86.3	25.13/0.71
1220-4-5P	23.8	13.8	11.9	2740	60/152.4	154/69.9	255/115.8	33.40/0.94
1220-5-6P	N/A	17.3	15.0	3440	73.75/187.3	188/85.4	290/131.7	40.75/1.15

*Measurements are approximate

Bid Specifications for Hot Food Merchandisers

The 2-Tier Hot Food Merchandiser shall be a Merco Model number _____, rated at _____ watts, _____ volts, single phase AC.

Standard equipment shall include

- EZ-Insert heat tubes in middle and upper level
- Insulated heat cable in bottom level
- Individual, infinitely adjustable heat controls – pilot lights for each level
- Bright incandescent illumination with on/off switches
- Removable sliding glass doors on cook-side and pop-out glass panels in front and ends
- Adjustable 4-inch NSF legs
- Pan rack as required
- 6-foot cordset

 **Merco Savory**

Enodis

1111 North Hadley Road
P.O. Box 1229
Fort Wayne, IN 46801-1229
Phone: (219) 459-8200 / Fax: (219) 459-8240
Toll Free 800 547-2513

Options & Accessories

Slant legs

Sled legs

Slant/sled legs

Two-way mirror-back doors

Sliding front doors

Hinged (lift-up) doors

Sign holder

Heat shields

Full- and half-size stainless steel pans

Full- and half-size grates

Merco Guarantee

Ninety (90) day warranty on labor, one (1) year on parts from date of purchase. Three (3) year warranty from date of purchase on heat tubes (excluding light bulbs).