



## Hot Food Merchandisers

1220-1P\*, 2P, 3P, 4P, 5P\* & 1826-1P\*, 2P, 3P

***Holds in the goodness without continued cooking or drying. Ideal for chicken, fish, ribs, french fries, biscuits, etc.***



Model 1220-3P Shown with Standard Pan Rack (pans are optional)

### Standard Features

- Merco's patented EZ-Insert® heat tubes in upper level
- Insulated heat cable in bottom level
- Individual, infinitely adjustable heat controls with pilot lights for each level
- Bright incandescent illumination with on/off switch
- Rugged stainless steel and aluminum construction
- Removable sliding glass doors on cook side (hinged lift-up doors on xxx-1P models)
- Pop-out glass panels in front and ends
- Pan rack as required (pans optional)
- Adjustable 4-inch NSF legs
- 6-foot cordset

Merco Hot Food Merchandisers are available in eight different models to meet any requirement. They are manufactured from heavy-duty stainless steel and specially selected aluminum alloys for long life and easy cleaning. All models feature Merco's patented EZ-Insert heat tubes in the upper level, matched with an insulated heat cable in the bottom level for gentle, yet thorough, warming. Individual, infinitely adjustable heat controls with pilot lights for each level let you "dial-in" the perfect temperature for any product. Bright incandescent illumination with on/off switch is provided to enhance the appearance of food. Removable sliding glass doors on cook side (hinged lift-up doors on xxx-1P models) and pop-out glass panels on front and ends for easy cleaning. Adjustable 4-inch NSF legs and 6-foot cordset are standard.

### Electrical Requirements

Available in 120, 120/208 or 120/240 VAC, single phase only (except xxx-1P models which are 120 VAC only).



1111 North Hadley Road  
P.O. Box 1229  
Fort Wayne, IN 46801-1229  
Phone: (260) 459-8200 / Fax: (260) 459-8240  
Toll Free 800 547-2513



Printed in USA,  
Designs and specifications are subject to change without notice  
© 2001 Merco Products, Inc., All Rights Reserved

# Hot Food Merchandisers

1220-1P, 2P, 3P, 4P, 5P & 1826-1P, 2P, 3P

## Dimensions (inches/cm)

MODEL #	DEPTH	HEIGHT
1220-xx	26.0/66.0	25.5/64.8
1826-xx	29.5/74.9	30.5/77.5

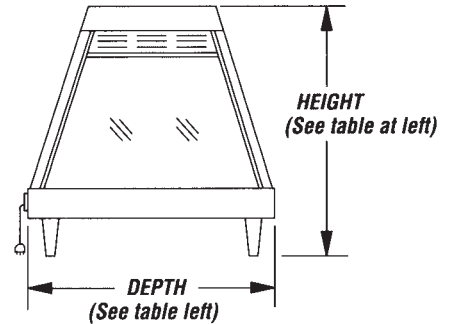
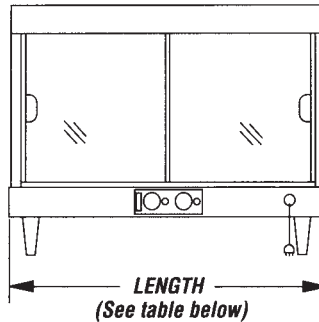

## Specifications (Standard models)

MODEL #	VOLTAGE/AMPS			WATTS	LENGTH inches/cm	NET WT.** lbs/kg	SHIP WT.** lbs/kg	SHIP VOL.* cu ft/cm
	120V	120/208V	120/240V					
1220-1P*†	7.2	N/A	N/A	860	16.5/41.9	53/24.1	90/40.9	8.6/0.24
1220-2P	10.3	6.0	5.2	1240	33/83.8	74/33.6	120/54.5	15.4/0.43
1220-3P	12.7	7.3	6.4	1485	44/111.8	102/46.3	145/65.8	20.4/0.57
1220-4P	18.3	10.6	9.2	2200	60/152.4	128/58.1	195/88.5	27/0.76
1220-5P*	21.4	12.4	10.7	2570	73.75/187.3	152/69.0	245/111.2	33/0.93
1826-1P*†	9.8	N/A	N/A	1170	21.5/54.6	68/30.9	105/47.7	15/0.43
1826-2P	12.7	7.3	6.4	1485	44/111.8	134/60.8	185/84.0	29/0.82
1826-3P	18.3	10.6	9.2	2200	60/152.4	192/87.2	230/104.4	38/1.08

\* 1220-1P, 1220-5P and 1826-1P are **not** CSA listed

† Models xxxx-1P have hinged lift-up doors standard (optional on other models)

\*\*Measurements are approximate

## Bid Specifications for Hot Food Merchandisers

The Hot Food Merchandiser shall be a Merco Model number \_\_\_\_\_, rated at \_\_\_\_\_ watts, \_\_\_\_\_ volts, single phase AC.

Standard equipment shall include

- EZ-Insert heat tubes in upper level
- Insulated heat cable in bottom level
- Lighted cabinet with on/off switch
- Removable glass doors on cook side
- Individual, infinitely adjustable heat controls with pilot lights for each level
- Adjustable 4-inch NSF legs
- Pan rack as required
- 6-foot cordset

## Options & Accessories

Slant legs

Sled legs

Slant/sled legs

Two-way mirror-back doors

Sliding front doors (for self-service)

Sign holder

Heat shields

Full- and half-size stainless steel pans

Full-size aluminum pans

Full- and half-size grates

## Merco Guarantee

Ninety (90) day warranty on labor, one (1) year on parts from date of purchase. Three (3) year warranty from date of purchase on heat tubes (excluding light bulbs).

 **Merco Savory**

Enodis

1111 North Hadley Road

P.O. Box 1229

Fort Wayne, IN 46801-1229

Phone: (260) 459-8200 / Fax: (260) 459-8240

Toll Free 800 547-2513