



QMVM-36L



QMVM-L SERIES

Quantum Series Medium Temp Low Profile Open Display Merchandisers

MODELS

- QMVM-36L
- QMVM-48L

FEATURES

STANDARD ELECTRONIC CONTROL

- Built in audible alarm with silence feature
- Easily monitor and set alarms, alarm delay and room temperature
- Decreases service time and calls
- Eliminates the need for a room thermostat, defrost termination/fan delay control, defrost timer and digital thermometer or other temperature indicator

CONSTRUCTION

- 24 gauge galvanized steel exterior and interior
- Shelves adjustable in 1" increments
- Two lighted tiers of two-position shelving standard
- Perforated interior back wall and top for better air flow
- Price tag molding
- 2" foamed-in-place "zero ODP" urethane insulation

FINISH

- White enamel interior and exterior
- Stainless steel floor pans (removable for easy service)

REFRIGERATION

- Refrigerant: R-134a
- Front air intake and rear air discharge
- Self-contained, bottom mount refrigeration system
- Minimum of 6" clearance between cabinet back and wall and a clearance of 10" at top
- Temperature range: 34° to 41°F (1° to 5°C)

- R-factor (insulation efficiency rating): 17.24
- **Drain plumbing hookup recommended. Condensate pan available if there is no access to drain plumbing.**

WARRANTY

- Standard limited four year extended compressor and one year limited parts and labor

OPTIONS

- Custom exterior and interior colors
- Condensate evaporator drain pan
- Condensate pump
- Product hooks
- Extra shelves (non-lighted)
- 1" vinyl bumper in choice of black, blue, brown, green, red or white



QMVM-L SERIES

QUANTUM SERIES MEDIUM TEMP LOW PROFILE OPEN DISPLAY MERCHANDISERS

TECHNICAL SPECIFICATIONS

MODEL	DIMENSIONS (in.)			DIMENSIONS (mm)			VOLTS	AMPS	UNIT H.P.	NO. OF SHELVES	STANDARD SHELF SIZE (in inches)	CAP. CU. FT.	SHIP CU. FT.	SHIP WT. LB/KG
	L	D	H	L	D	H								
QMVM-36L	36	30	60	914	762	1524	115	14.8	1/2	2	14 x 31 ¹ / ₈	11.2	67.0	490/223
QMVM-48L	48	30	60	1219	762	1524	115	14.9	3/4	2	14 x 43 ¹ / ₈	15.4	81.0	580/264

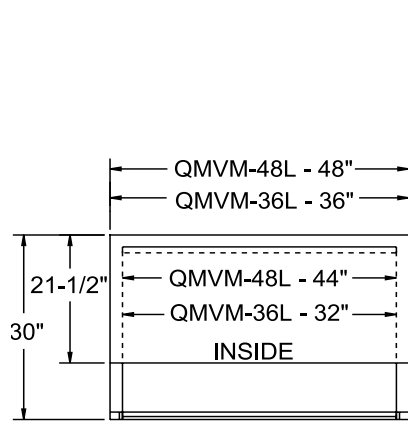

PLAN VIEW

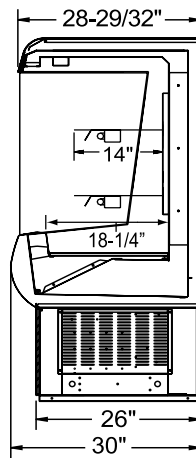

SIDE VIEW

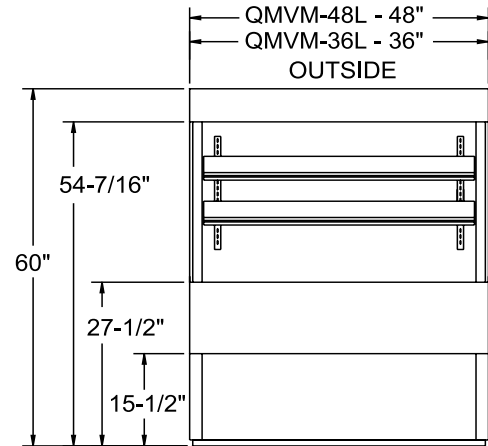

ELEVATION VIEW

LISTINGS



HOOKUP

Electrical hookup: 115v
 Plumbing hookup: Requires connection to customer's drain

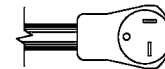

NEMA 5-20P

RECOMMENDED OPERATING CONDITIONS

- Merchandisers designed to hold product in the 34° to 41°F (1° to 5°C) range
- Designed to operate in air-conditioned stores where the maximum temperature is 75°F and the maximum relative humidity is 55%
- Should not be installed in direct sunlight
- Should not be installed near HVAC vents, fans or doorways that will disrupt airflow and compromise the function of the air screen inside the case
- Bottom shelf should not be loaded such that the front air intake is obstructed
- Floor drain should be properly trapped
- Factory installed controls should not be altered, removed or replaced without consent of the factory
- Product must not be displayed in the cold air curtain

BID SPECIFICATIONS

Item no. QMVM-____L
 Provide _____ () Quantum Series Medium Temp Low Profile Open Display Merchandiser(s), Master-Bilt model no. QMVM-____L.
 Merchandiser to have standard electronic controller eliminating the need for a room thermostat, defrost termination/fan delay control, defrost timer and digital thermom-

eter or other temperature indicator.
 Merchandiser to have two-position shelves adjustable in 1" increments, perforated interior back wall, independent shelf lighting and price tag molding. Merchandiser will also contain 2" foamed-in-place "zero ODP" urethane insulation.
 The refrigeration system is to be self-contained, with front condenser air intake and

rear air discharge and use R-134a refrigerant. The temperature range is 34° to 41°F (1° to 5°C). Merchandiser to have standard limited 4 year extended compressor warranty and 1 year limited parts and labor warranty. It is also to be UL and C-UL listed and UL EPH classified.



908 Highway 15 North • New Albany, MS 38652
 PHONE: 800-647-1284 or 662-534-9061 • FAX: 800-232-3966 or 662-534-6049 • www.master-bilt.com

All specifications subject to change without notice.

