



MSF-52

Standard features include deep angled baskets, basket dividers, thermometer and lock.

MB MASTER-BILT[®]

COLDIN-2[™] SERIES

MSF SERIES

Flat Lid Display Freezers

MODELS

- MSF-30
- MSF-41
- MSF-52
- MSF-70

FEATURES

CONSTRUCTION

- Anti-fog tempered glass sliding lids
- White powder-coated baked-on enamel exterior
- Painted white powder-coated aluminum interior
- Heavy-duty 2" casters, two locking
- Bottom drain with plug
- The unobtrusive frame around the heated glass lids ensures a highly visible display

- Low energy consumption
- 2³/₈" insulation in sides, 2" in bottom

REFRIGERATION

- Refrigerant:
 - All models except MSF-70 ... R-134a
 - MSF-70 R-404A
- Temperature range:
 - 18° to 10°F (-27° to -12°C)
- R-factor (insulation efficiency rating): 17.24

WARRANTY

- Standard limited four year extended compressor and one year limited parts and labor

STANDARD BASKET CONFIGURATIONS

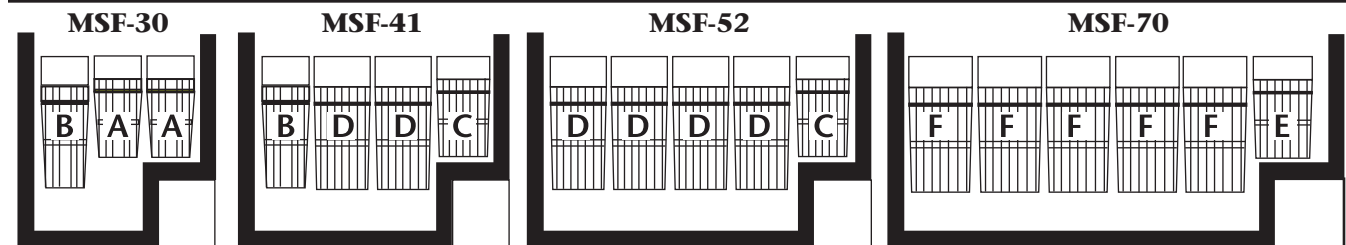

- A** = Basket with dimensions of 8"W x 21³/₄"D x 12"H (includes one transversal divider)
- B** = Basket with dimensions of 8"W x 21³/₄"D x 18"H (includes one transversal divider)
- C** = Basket with dimensions of 9"W x 21³/₄"D x 12"H (includes one transversal divider)
- D** = Basket with dimensions of 9"W x 21³/₄"D x 18"H (includes one transversal divider)
- E** = Basket with dimensions of 10¹/₂"W x 21³/₄"D x 12"H (includes one transversal divider)
- F** = Basket with dimensions of 10¹/₂"W x 21³/₄"D x 18"H (includes one transversal divider)



COLDIN-2™ MSF SERIES FLAT LID DISPLAY FREEZERS

TECHNICAL SPECIFICATIONS

MODEL	DIMENSIONS (in.)			DIMENSIONS (mm)			VOLTS	AMPS	UNIT H.P.	GROSS CU. FT.	NET CU. FT.	SHIP CU. FT.	SHIP WT. LB/KG
	L	D	H	L	D	H							
MSF-30	29 ¹ / ₂	25 ³ / ₄	35 ¹ / ₂	749	654	902	115	3.0	1/4	7.8	6.4	22.9	154/70
MSF-41	41	25 ³ / ₄	35 ¹ / ₂	1041	654	902	115	4.0	1/3	11.9	9.9	31.0	188/85
MSF-52	51 ¹ / ₂	25 ³ / ₄	35 ¹ / ₂	1308	654	902	115	5.0	1/3	15.6	13.0	38.4	213/97
MSF-70	69 ³ / ₄	25 ³ / ₄	35 ¹ / ₂	1772	654	902	115	6.0	3/8	22.2	18.6	50.9	276/125

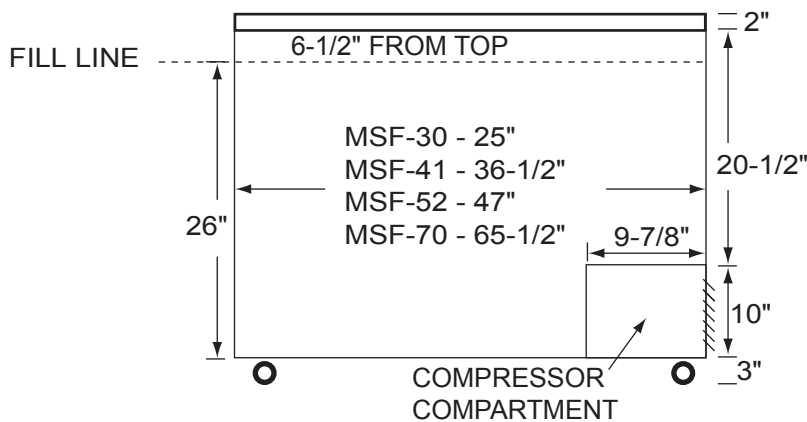

ELEVATION VIEW

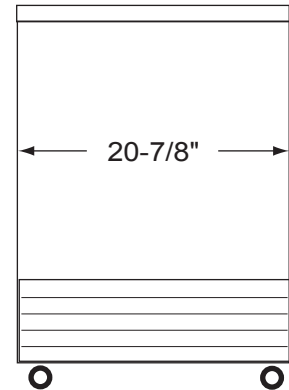

SIDE VIEW

LISTINGS



HOOKUP

Via plug in, 5¹/₂ foot long, flexible 3 wire 14AWG/3 cord with molded plug.



BID SPECIFICATIONS

Item no. MSF-_____
Provide _____ () Standard Display Freezer(s) Master-Bilt model MSF-_____.

Freezer to be constructed of a white powder-coated baked-on enamel on steel exterior with painted white powder-coated aluminum interior. Sides of freezer will

contain 2³/₈" insulation with 2" insulation in bottoms. Freezer to be furnished standard with baskets, basket dividers, thermometer and lock. Additionally, it will be provided with heavy-duty 2" casters and a defrost water drain. Lids will contain safety glass.

Refrigeration system will use R-134a re-

frigerant in all models except MSF-70 which will contain R404A. The temperature range will be -18° to 10°F (-27° to -12°C).

Freezer to have standard limited four year extended compressor warranty and one year limited parts and labor. Freezer to be ETL listed in the U.S. and Canada and ETL Sanitation listed.

NOTE: Cabinet designed for optimum performance in air-conditioned area at 75°F ambient and 55% relative humidity. All specifications subject to change without notice.



908 Highway 15 North • New Albany, MS 38652
PHONE: 800-647-1284 or 662-534-9061 • FAX: 800-232-3966 or 662-534-6049 • www.master-bilt.com

