



MPM-48

MPM SERIES

Medium Temp Open Display Merchandisers

MODELS

- MPM-36
- MPM-48
- MPM-72

FEATURES

CONSTRUCTION

- 24 gauge painted steel interior and exterior
- Removable two tier stainless steel display deck
- Full length 8³/₄" wide laminated white formica counter top
- Front bumper guard
- Automatic defrost
- On/off power switch on MPM-36 and MPM-48
- Cord and plug on MPM-36 and MPM-48
- Black vinyl trim
- 2" foamed-in-place "zero ODP" urethane insulation

FINISH

- White enamel interior and exterior
- Stainless steel floor

REFRIGERATION

- Refrigerant: R-134a
- Front air intake and rear discharge
- Electric condensate evaporator (MPM-72 requires a separate 115V power supply for evaporator)
- Forced air ducted flow
- Self-contained, bottom mount refrigeration system
- Minimum of 6" clearance between cabinet back and wall and a clearance of 10" at top
- Temperature range: 34° to 41°F (1° to 5°C)
- R-factor (insulation efficiency rating): 17.24
- Slide-out refrigeration system

WARRANTY

- Standard limited four year extended compressor and one year limited parts and labor

OPTIONS

- Add suffix "SS" for stainless steel interior and exterior
- Custom colors
- Night curtain kit (factory installed)
- Light kit (factory installed)
- Night curtain & light kit (factory installed)
- Casters
- Sandwich racks
- Sandwich rack dividers



MPM SERIES MEDIUM TEMP OPEN DISPLAY MERCHANDISERS

TECHNICAL SPECIFICATIONS

MODEL	DIMENSIONS (in.)			DIMENSIONS (mm)			VOLTS	AMPS	UNIT H.P.	CAP. CU. FT.	SHIP CU. FT.	SHIP WT. LB/KG
	L	D	H	L	D	H						
MPM-36	36	30 ¹ / ₂	43 ¹ / ₄	914	787	1099	115	10.3	1/3	3.7	41.0	310/141
MPM-48	48	30 ¹ / ₂	43 ¹ / ₄	1219	787	1099	115	15.5	1/2	5.1	53.0	410/220
MPM-72	72	30 ¹ / ₂	43 ¹ / ₄	1829	787	1099	115/115*	15.8/10.4*	3/4	7.9	86.0	590/268

*Electric condensate evaporator requires separate power supply.

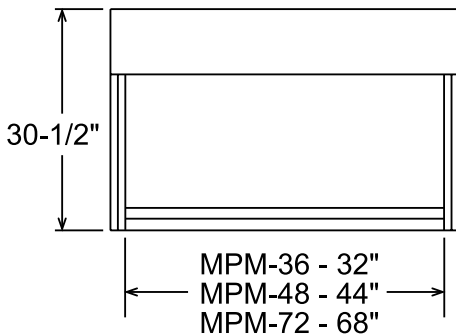

PLAN VIEW

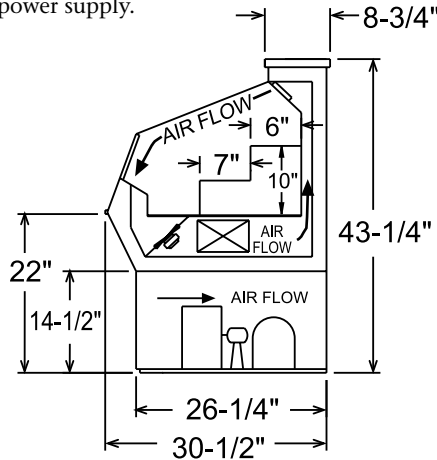

SIDE VIEW

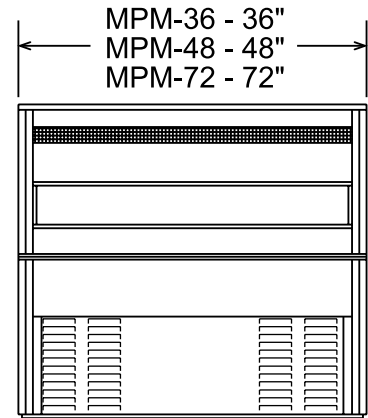

ELEVATION VIEW

LISTINGS



HOOKUP

MPM-36 and MPM-48 via plug-in, 9 foot long, flexible three wire 14/3 cord with molded plug. MPM-72 model hardwired with separate 115V junction boxes for cabinet and condensate evaporator.

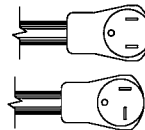

NEMA 5-15P (MPM-36)

NEMA 5-20P (MPM-48)

RECOMMENDED OPERATING CONDITIONS

- Merchandisers designed to hold product in the 34° to 41°F (1° to 5°C) range
- Designed to operate in air-conditioned stores where the maximum temperature is 75°F and the maximum relative humidity is 55%
- Should not be installed in direct sunlight
- Should not be installed near HVAC vents, fans or doorways that will disrupt airflow and compromise the function of the air screen inside the case
- Bottom shelf should not be loaded such that the front air intake is obstructed
- Factory installed controls should not be altered, removed or replaced without consent of the factory
- Product must not be displayed in the cold air curtain

BID SPECIFICATIONS

Item no. MPM-_____
Provide _____ () Medium Temp Open Display Merchandiser(s), Master-Bilt model no. MPM-_____.

Merchandiser to have removable two tier stainless steel display deck, full length

8³/₄" wide laminated white formica counter top, front bumper guard, automatic defrost, on/off power switch (MPM-36 and MPM-48 only), black vinyl trim and have foamed-in-place "zero ODP" urethane insulation. The temperature range of the

merchandiser will be 34° to 41°F (1° to 5°C). Merchandiser to have standard limited four year extended compressor warranty and one year limited parts and labor warranty. Merchandiser to be UL and C-UL listed and UL EPH classified.

NOTE: All specifications subject to change without notice.



908 Highway 15 North • New Albany, MS 38652
PHONE: 800-647-1284 or 662-534-9061 • FAX: 800-232-3966 or 662-534-6049 • www.master-bilt.com

