



BGR-14

BGR-14 SERIES

Bottom Mounted Glass Door Refrigerator

MODELS

- BGR-14

FEATURES

CONSTRUCTION

- Cabinet interior constructed of durable ABS sheets
- Seven white epoxy-coated, heavy-duty, welded wire shelves (six top and one bottom)
- Foamed-in-place "low ODP" urethane insulation
- Interior fluorescent lamp
- Fluorescent lit promotional graphic panel
- Adjustable leveling legs
- Condensate evaporator

FINISH

- White epoxy polyester exterior finish (powder coated)

DOORS

- Door size:.....23³/₈ x 53"
- Black door frame
- Auto-close, double pane, glass doors with thermal insulating film
- Hold-open feature
- Replaceable door gaskets

REFRIGERATION

- Self-contained, factory tested, bottom mounted refrigeration system
- Slide-out system for easy access
- Top mounted low profile interior fan housing
- Minimum 4" clearance required between cabinet back and wall

- Refrigerant: R-134a
- Temperature range: 34° to 41°F (1° to 5°C)
- R-factor (insulation efficiency rating): 18.75

WARRANTY

- Standard limited four year extended compressor and one year limited parts and labor



BGR-14 SERIES BOTTOM MOUNTED GLASS DOOR REFRIGERATOR

TECHNICAL SPECIFICATIONS

MODEL	DIMENSIONS (in.)			DIMENSIONS (mm)			VOLTS	AMPS	UNIT H.P.	NO. OF DOORS	CAP. CU. FT.	SHIP CU. FT.	SHIP WT. (LB/KG)
	L	D	H	L	D	H							
BGR-14	23 ⁵ / ₈	26 ¹ / ₈	74	600	664	1880	115	6.3	1/4	1	12.3	32.9	200/91

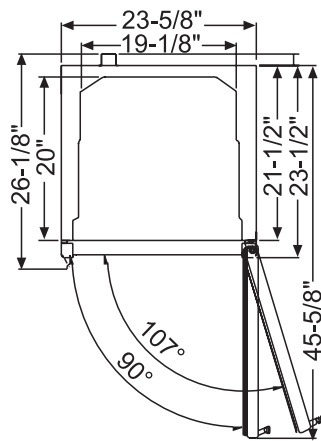

PLAN VIEW

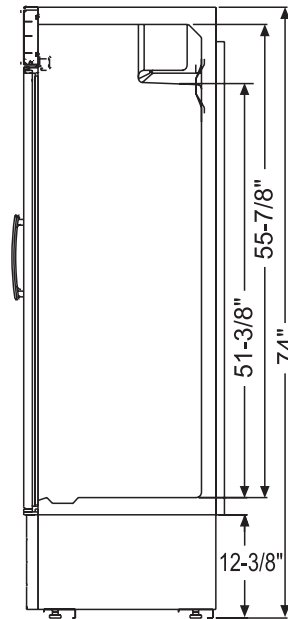

SIDE VIEW

LISTINGS



California Energy Commission Certified

HOOKUP

Via plug in, 5 foot long, flexible 18/3 cord with molded plug.



BID SPECIFICATIONS

Item no. BGR-14.

Provide _____ () Bottom Mounted Glass Door Refrigerator(s), Master-Bilt model no. BGR-14.

Refrigerator interior to be constructed of durable ABS sheets. Standard features will include: Seven white epoxy-coated, heavy-duty, welded wire shelves; foamed-in-place "low ODP" urethane insulation; an interior

fluorescent lamp and fluorescent lit promotional graphic panel. Refrigerator will also be provided with adjustable leveling legs and a condensate evaporator.

Refrigerator door will be constructed with double pane glass with thermal insulating film. Door will also be auto-closing with a hold-open feature and replaceable gaskets.

The refrigeration system will be self-con-

tained, factory tested and bottom mounted. The system will also slide-out for easy access. Refrigerant type will be R-134a. Temperature range will be 34° to 41°F (1° to 5°C).

Refrigerator to have standard limited four year extended compressor warranty and one year limited parts and labor warranty.

Freezer to be UL, C-UL and NSF listed also California Energy Commission certified.

NOTE: Cabinet designed for optimum performance in air-conditioned area at 75°F ambient and 55% relative humidity. All specifications subject to change without notice.



908 Highway 15 North • New Albany, MS 38652
PHONE: 800-647-1284 or 662-534-9061 • FAX: 800-232-3966 or 662-534-6049 • www.master-bilt.com

