

# Jackson

## TempStar™

Project \_\_\_\_\_  
 Item \_\_\_\_\_  
 Quantity \_\_\_\_\_  
 CSI Section 11400 \_\_\_\_\_  
 Approval \_\_\_\_\_  
 Date \_\_\_\_\_

### Models

- TempStar™ (70°F-rise Booster)     TempStar™ (40°F-rise Booster)     TempStar™ with No Booster



### Standard Features

- Energy Star® qualified
- Sani-Sure™ feature assures proper rinse-water temperature
- Multi-cycle timer (Extra Heavy, Heavy, Medium, Normal)
- Specially designed stainless steel nozzles result in superior cleaning
- 17" (432 mm) door opening accepts 18" (457 mm) trays
- Ultra-efficient (patent pending) rinse arms also cut water usage
- Auto-fill, auto-start
- Safety door switch
- Delime/manual wash switch
- Low-watt density electric wash tank heater
- Hi-limit thermostat and low-water protection
- Top-mounted controls for ease of installation and operation
- Adjustable bullet feet
- Uses standard 20" X 20" (508 mm X 508 mm) racks
- Front dress panel
- Detergent/rinse additive signal connection fuse box
- Self-draining stainless steel pump
- Built-in 70°F- (21°C- ) rise booster heater part of Sani-Sure™ feature and standard
- Large scrap tray

### Mandatory Specs

- Specify voltage  
 Specify booster size  
 Specify electric or steam heat

### Optional Features

- 40°F- (4°C- ) rise booster heater available at no additional cost if specified at time of order
- With no booster heater  
 Drain quench system  
 Scaltrol  
 Water hammer arrestor  
 Flanged feet

### Accessories

- 36" (914 mm) compartment rack 4-1/6" (4 mm) tall  
 36" (914 mm) compartment rack 5-5/8" (16 mm) tall  
 36" (914 mm) compartment rack 7" (178 mm) tall
- Combination rack  
 Peg rack

### Specifications

Uses 0.90 gallon (3.4 liters) of water per rack

Total automatic (normal) cycle - 68 seconds

50 racks per hour (normal) cycle

3/4 HP wash pump motor

Single-point connections for all utilities

Built-in water- pressure regulator and gauge

Field convertible from straight through to corner operations

Heavy duty stainless steel construction



**SHIPPING ADDRESS**  
 6209 North U.S. Highway 25E  
 Gray, KY 40734

**MAILING ADDRESS**  
 P. O. Box 1060  
 Barboursville, KY 40906

Tel: 606-523-9795  
 Tel: 1-888-800-5672  
 Fax: 606-523-1799

[www.jacksonmsc.com](http://www.jacksonmsc.com)  
 E-mail: [customerservice@jacksonmsc.com](mailto:customerservice@jacksonmsc.com)  
 07610-003-60-59 (11/08)



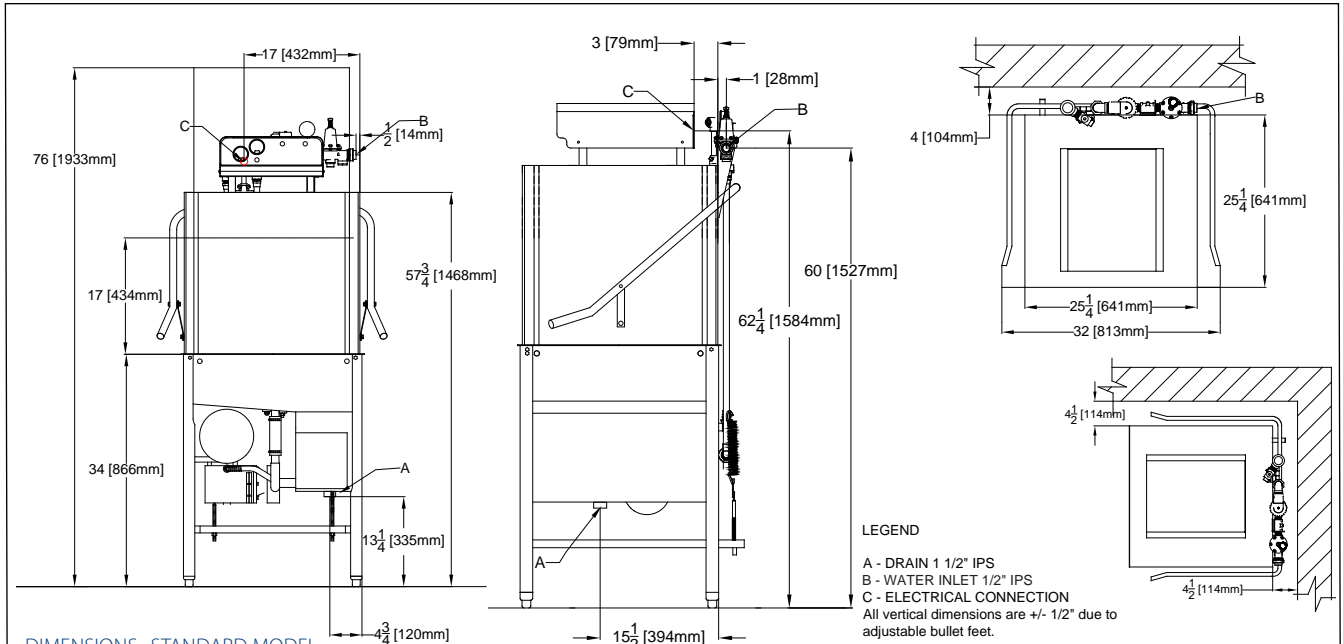

DIMENSIONS--STANDARD MODEL

MODEL NO.	SIZE			DRAIN HEIGHT	SHIPPING INFO			DIMENSIONS		
	HEIGHT	WIDTH	DEPTH		WEIGHT	CLASS	CUBE	HEIGHT	WIDTH	DEPTH
TempStar™	64-3/8" (1635 mm)	25-1/4" (641 mm)	25-1/4" (641 mm)	13-1/4" (335 mm)	350 lbs (159 kg)	92.5	37-1/2 cu. ft.	72" (1829 mm)	30" (762 mm)	30" (762 mm)

DIMENSION REQUIREMENTS

Wall Clearance (Minimum)	4" / (102 mm)
Standard Table Height	34" / (864 mm)
Inside Chamber Clearance	17-1/4" / (438 mm)

STEAM REQUIREMENTS

Steam Flow Pressure (PSIG)	15-20
Consumption @ 15 PSIG (lbs./hr.)	45

OPERATING CAPACITY

Racks per Hour	Normal 50	Medium 29	Heavy 19	Extra Heavy 11
OPERATING CYCLE (sec)	Wash	Rinse	Dwell	Total Cycle
Normal	45	11	12	68
Medium	103	11	12	126
Heavy	163	11	12	186
Extra Heavy	283	11	12	306

WATER REQUIREMENTS

Inlet Temperature	
40°F / (4°C) Rise	140°F / (82°C)
70°F / (21°C) Rise	110°F / (60°C)
Gallons per Hour	45 / (170 Ltr.)
Gallons per Rack	0.90 / (3.4 Ltr)
Waterline Size IPS (Minimum-Inches)	1/2
Drainline Size IPS (Minimum-Inches)	1-1/2
Flow Pressure (PSI)	8
Wash Tank Capacity	8 Gal. / (30 Ltr)
Booster Tank Capacity	3 Gal. / (11 Ltr)

OPERATING TEMPERATURES

Wash (Minimum)	150°F / (66°C)
Rinse (Minimum)	180°F / (82°C)

COMPONENT SPECIFICATIONS

Wash Pump Motor Horsepower		3/4 HP
	Volts	kW
Electric Wash Tank Heater	208V	4.1
	230V	5.0
	460V	5.0
Electric Rinse Tank Heater 40°F (4°C) Rise	208V	9.0
	230V	11.0
	460V	11.0
	70°F (21°C) Rise	208V 10.5
		230V 12.9
		460V 12.9

APPROXIMATE LOAD AMPS

	No Booster	40°F (4°C) Rise	70°F (21°C) Rise
Power Supply	AMPS	AMPS	AMPS
208V/60HZ/1PH	24.6	68.7	75.8
208V/60HZ/3PH	26.6	42.1	46.3
230V/60HZ/1PH	16.3	75.4	83.6
230V/60HZ/3PH	17.5	45.5	50.7
460V/60HZ/3PH	7.9	21.7	24.1

How To Specify - TSTAR-A-7 for TempStar™ (70°F-rise Booster Heater)  
 TSTAR-A for TempStar™ (40°F-rise Booster Heater)  
 TSTAR-A-NB for TempStar™ with no Booster Heater

**SHIPPING ADDRESS**  
 6209 North U.S. Highway 25E  
 Gray, KY 40734

**MAILING ADDRESS**  
 P. O. Box 1060  
 Barboursville, KY 40906

**Tel: 606-523-9795**  
**Tel: 1-888-800-5672**  
**Fax: 606-523-1799**

**www.jacksonmsc.com**  
**E-mail: customerservice@jacksonmsc.com**  
**07610-003-60-59 (11/08)**

