

# Jackson Conservar™ AXL

Project \_\_\_\_\_  
 Item \_\_\_\_\_  
 Quantity \_\_\_\_\_  
 CSI Section 11400 \_\_\_\_\_  
 Approval \_\_\_\_\_  
 Date \_\_\_\_\_

## Models

Conservar™ AXL



## Standard Features

- Universal timer
- Built in waste accumulator
- 3" (76 mm) stainless steel adjustable bullet feet
- Delimer switch for easy removal of hard water deposits
- Removable scrap screen
- Three selectable timer cycles
- Air gap instead of vacuum breaker
- Door safety switch
- Convenient top mounted controls
- Auto start
- Interchangeable stainless steel arms

## Mandatory Specs

- Specify voltage

## Optional Features

Solid bowl option

## Accessory Items

- 36 Compartment racks (4-1/8", 5-5/8", or 7") (105 mm, 143 mm, 178 mm)
- Combination rack
- Peg rack
- Sanitizer alarm
- Scaltrol
- Water hammer arrestor

## Specifications

Uses 1.5 gallons (6 liters) of water per rack

37 racks per hour

Single point electrical connection

Self-draining stainless steel pump eliminates soil/detergent carryover between wash and rinse cycles

Dump and fill feature disposes of dirty water, replacing it with a fresh water rinse every cycle

Field convertible from straight to corner and corner to straight for flexible installations and applications.

Dual-point drain connections allow for versatile installations

17-1/4" (438 mm) vertical inside clearance

3 built-in dispensing pumps for detergent, rinse agent and sanitizer are controlled by individual priming switches

Fully automatic timed cycles - 90 seconds, 3 minutes or 5 minutes

Large removable scrap screen

Heavy duty stainless steel construction



Highway 25E  
 P. O. Box 1060  
 Barbourville, KY 40906

Tel: 606-523-9795  
 Tel: 1-888-800-5672  
 Fax: 606-523-9196  
 E-mail: [info@jacksonmsc.com](mailto:info@jacksonmsc.com)

[www.jacksonmsc.com](http://www.jacksonmsc.com)  
 07610-003-38-80 (08/07)

Enodis

**LEGEND:**

- A - Electrical connection
- B - Water inlet 1/2" I.P.S
- C - Drain connection 2" I.P.S

All vertical dimensions are +/- 1/2" from floor due to adjustable bullet feet.

Standard clearance between the wall and the machine with dishtable is 4".

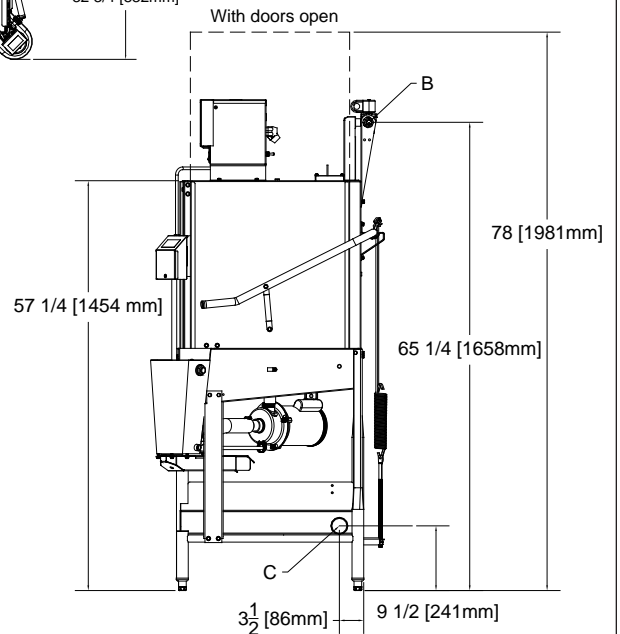
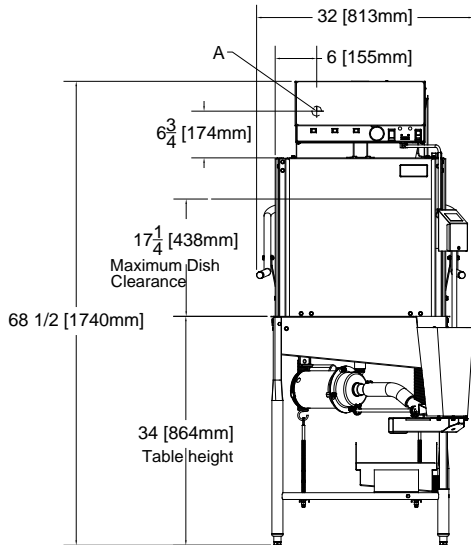
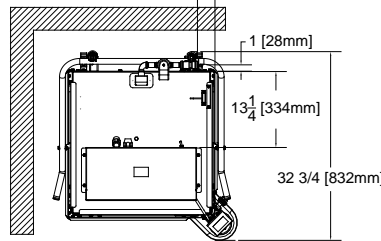

**POWER REQUIREMENTS**

MODEL	ELECTRICAL REQUIREMENT	SERVICE BREAKER SIZE
Conservor™ AXL	115v/60~1ø-11.4A	15A

**WATER REQUIREMENTS**

	MINIMUM	RECOMMENDED
Inlet Temperature	120°F 49°C	140°F 60°C
Wash Operating Temperatures	120°F 49°C	140°F 60°C
Rinse Operating Temperatures	120°F 49°C	140°F 60°C

**PERFORMANCE CAPABILITIES**

Flow Pressure (PSI)	15-25
Wash Pump Motor Horsepower	3/4
Pump Capacity (GPM)	55
Minimum Chlorine Required (PPM)	50

**Legend**

- A - Electrical Connection
- B - Water Connection, 1/4"

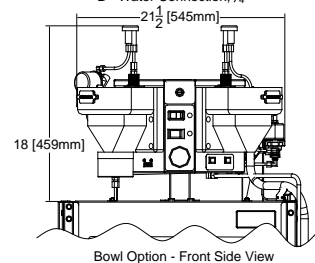

Bowl Option - Front Side View

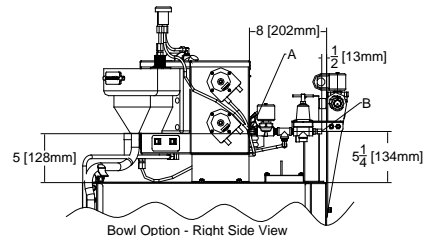

Bowl Option - Right Side View

**DIMENSIONS--STANDARD MODEL**

MODEL NO.	SIZE			DRAIN HEIGHT	SHIPPING INFO			DIMENSIONS		
	HEIGHT	WIDTH	DEPTH		WEIGHT	CLASS	CUBE	HEIGHT	WIDTH	DEPTH
Conservor™ AXL	68-1/2" (1740 mm)	32" (813 mm)	32-3/4" (832 mm)	9-1/2" (241 mm)	280 lbs (127 kg)	92.5	44.7 cu. ft.	78" (1981 mm)	33" (838 mm)	30" (762 mm)

**HOW TO SPECIFY - EXAMPLE:**

Conservor™ AXL - Chemical sanitizing, 115 volt, 1 phase

Highway 25E  
P. O. Box 1060  
Barbourville, KY 40906

Tel: 606-523-9795  
Tel: 1-888-800-5672  
Fax: 606-523-9196  
E-mail: info@jacksonmsc.com

www.jacksonmsc.com  
07610-003-38-80 (08/07)