

HOBART701 S Ridge Avenue, Troy, OH 45374
1-888-4HOBART • www.hobartcorp.com**THE EDGE™
SLICER****HOBART****STANDARD FEATURES**

- 1/3 H.P. Knife Drive Motor
- Gauge Plate Interlock
- Carriage System Interlock
- Removable Carriage System
- Contoured Carbon Steel Knife
- Top Mounted Borazon Stone Sharpener
- Poly V-Belt Drive System
- Patented Belt Tensioner
- Sanitary Anodized Aluminum Base
- Permanently Mounted Ring Guard
- Cleaning Leg
- Removable Product Deflector
- Anodized Aluminum Carriage and Knife Cover
- Rear Mounted Meat Grip
- Knife Shaft Cleaning Brush

MODEL

- The Edge™ Slicer – 120/60/1, Manual Slicer and 12" Knife

Specifications, Details and Dimensions on Inside and Back.

**THE EDGE™
SLICER**

SOLUTIONS / BENEFITS

1/3 H.P. Knife Drive Motor

Durability, performance

- Reserve power runs at 370 rpm for optimum results

Gauge Plate Interlock

Ease of cleaning

- Gauge plate must be closed to remove carriage for cleaning and cannot be opened when carriage is removed
- Protects knife edge during cleaning procedures

Carriage System Interlock

- Will not remove if gauge plate indicator is not closed

Removable Carriage System

Improves sanitation

- Removable for complete cleaning and sanitation procedures

Contoured Carbon Steel Knife

Reduced cost of ownership, improved yield

- Thin edge design improves yield

Top Mounted Borazon Stone Sharpener

Ease of use, improved sanitation

- Single action sharpens and hones in just five seconds
- Removable and submersible for easy cleaning and sanitation

Poly V-Belt Drive System

Performance, durability, reduced maintenance

- Design extends belt life while producing optimal slicing results
- Quieter operating slicer
- More economical for service and repairs with reduced parts and reduced service time

Sanitary Anodized Aluminum Base

Improved sanitation, labor savings

- One piece base protects against possible growth of bacteria
- No cracks/crevices or bolt holes where product can lodge and bacteria may grow
- Easy cleanup and durable finish

Permanently Mounted Ring Guard

Protection

- Protects knife during operation and cleaning

Cleaning Leg

Improved sanitation, ease of use

- Props machine for easy cleaning underneath slicer

Removable Rear Deflector

Improved sanitation, ease of use

- Allows access for thorough cleaning
- No tools required means easy removal during cleaning

Anodized Aluminum Carriage and Knife Cover

Improved sanitation, durability

- Maximum sanitation with minimum cleanup time
- Corrosion resistant, impact resistant



701 S Ridge Avenue, Troy, OH 45374
1-888-4HOBART • www.hobartcorp.com

THE EDGE™ SLICER

SPECIFICATIONS

KNIFE MOTOR: 1/3 H.P., permanently lubricated ball bearings. Single phase capacitor-start, induction run. 3.5 AMP

GAUGE PLATE INTERLOCK: Gauge plate interlock protects knife edge when indicator is closed.

CARRIAGE SYSTEM INTERLOCK: Carriage will not remove if gauge plate not closed.

REMOVABLE CARRIAGE SYSTEM: Positive angle carriage design enables operator to slice without manual feed. The anodized aluminum carriage system is removable for thorough cleaning and sanitation procedures. The carriage has 9 3/4" manual travel.

CONTOURED CARBON STEEL KNIFE: Carbon steel, 1 1/4" diameter with sanitary hub. Knife is protected by a permanently mounted ring guard. The anodized aluminum knife cover provides easy access for cleaning. Gauge plate protects knife edge when indicator is closed.

TOP MOUNTED BORAZON STONE SHARPENER: One lever operation utilizing two Borazon stones to sharpen and hone in five seconds. Removable and top mounted. When sharpener is removed for cleaning, knife edge is shielded.

POLY V-BELT DRIVE SYSTEM: Knife is driven by a Poly V belt and runs at 370 rpm for optimal performance. Aluminum knife shaft pulley and steel motor pulley.

SANITARY ANODIZED ALUMINUM BASE: One-piece base protects against possible growth of bacteria. All surfaces are durable and smooth, presenting no holes or crevices in which food can lodge. Easy clean-up and durable finish to withstand harsh cleaning products.

PERMANENTLY MOUNTED RING GUARD: Permanently mounted ring guard with integrated product deflector protects knife during operation and cleaning.

CLEANING LEG: Cleaning leg supports the slicer in tilted position for cleaning beneath the machine.

REMOVABLE REAR DEFLECTOR: No tools are required for removal of the deflector for thorough cleaning of the slicer.

FINISH: Anodized aluminum carriage, gauge plate, knife cover and base.

MEAT GRIP: Rear mounted grip is anodized aluminum. Swings out of way when not in use.

ELECTRICAL SPECIFICATIONS: 120/60/1 – UL Listed.

SWITCH: Moisture protected toggle type.

CORD & PLUG: 6-foot, three-wire power supply cord and plug.

CAPACITY: The carriage will take food up to 7 1/4" in width or 7 3/4" in diameter.

GAUGE PLATE: Gauge plate is a heavy anodized aluminum casting with ribbed face for smooth feeding. Adjustable to cut any thickness of slice up to 5/8".

WARRANTY: All parts and service coverage for one year including knife.

WEIGHT: Shipping 83 lbs., Net 63 lbs.

THE EDGE™ SLICER



701 S Ridge Avenue, Troy, OH 45374
1-888-4HOBART • www.hobartcorp.com

DETAILS AND DIMENSIONS

LEGEND

E1- ELECTRICAL CONNECTION, APPROX 1" ABOVE COUNTER TOP

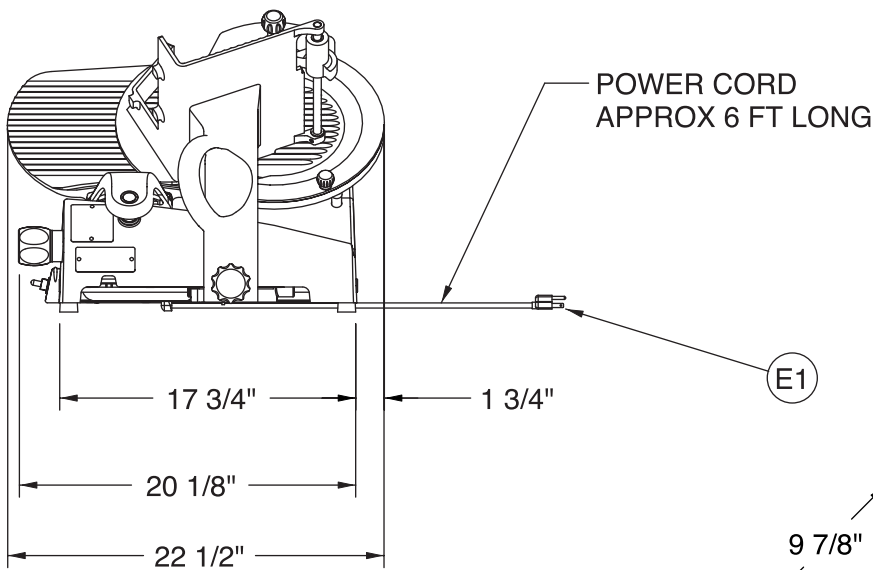
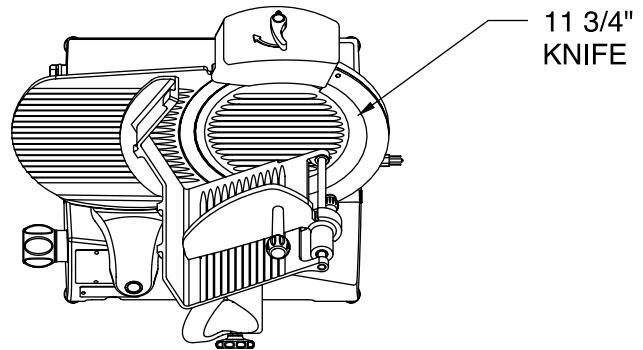

AVAILABLE ELECTRICAL CONFIGURATIONS

120v, 60Hz, 1 PH, 3.5 amps

WARNING

ELECTRICAL AND GROUNDING CONNECTIONS
MUST COMPLY WITH THE APPLICABLE PORTIONS
OF THE NATIONAL ELECTRICAL CODE AND/OR
OTHER LOCAL ELECTRICAL CODES

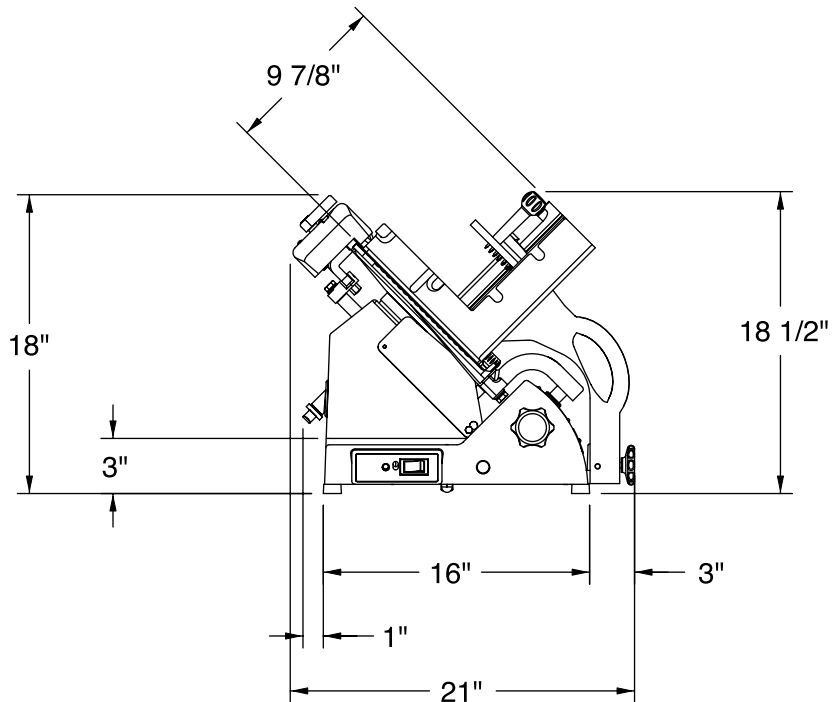

As continued product improvement is a policy of Hobart, specifications are subject to change without notice.