



2712 SLICER

HOBART

STANDARD FEATURES

- MICROBAN® Antimicrobial Product Protection
- Two-Speed Automatic Carriage with Front Mounted Controls
- Exclusive Tilting, Removable Carriage System
- Contoured Cast Stainless Steel Stay Sharp™ Knife
- Top Mounted Borazon Stone Sharpener
- Hobart Poly V-Belt Drive System
- Sanitary Burnished Aluminum Base
- Double-Action Indexing Cam
- Permanently Mounted Ring Guard
- Heavy Gauge Stainless Steel Top Cover with Integrated Product Deflector
- Lift Lever
- Removable Rear Deflector
- ½ H.P. Knife Drive Motor
- Nylon Carriage Roller
- Electroless Nickel Plated Single Slide Rod with Reservoir Wick
- Stainless Steel Carriage and Knife Cover
- Ergonomic Style Handle
- Low Fence

ACCESSORIES

- Low Fence
- High Fence
- Food Chute
- Heavy Meat Grip with Clips
- Heavy Handle
- 4" Legs
- Product Tray

MODEL

- 2712 – Basic Automatic Slicer with the Works
- 2712C – Basic Automatic Slicer with Maximum Security Correctional Package (120/60/1 only)

2712 SLICER

SOLUTIONS / BENEFITS

Microban® Antimicrobial Product Protection

Cleaner Between Cleanings

- Inhibits the growth of bacteria, mold, mildew and fungi, keeping the slicer “cleaner between cleanings”
- Built-in and designed to last the life of the product
- Works continuously between cleanings to maintain a lower level of odor and stain causing microorganisms

Two-Speed Automatic Carriage with Front Mounted Controls

Offers flexibility, ease of use, performance, increased productivity

- Supports automatic with 2 speed choices or manual mode
- Two speed selector front mounted

Exclusive Tilting, Removable Carriage System

Reduces labor, improves sanitation

- Tilt design allows for ease of midday cleaning
- Removable for complete cleaning and sanitation procedures

Contoured Cast Stainless Steel Stay Sharp Knife

Reduced cost of ownership, improved yield

- Thin edge design improves yield
- Reduced maintenance cost with knife warranty

Top Mounted Borazon Stone Sharpener

Ease of use, improved sanitation, reduced costs

- Single action sharpens and hones in just five seconds
- Removable and submersible for easy cleaning and sanitation
- Lifetime guaranteed Borazon sharpening stones provide maximum performance with reduced maintenance costs

Poly V-Belt Drive System

Performance, durability, reduced maintenance

- Quieter operating slicer
- Patented design extends belt life while producing optimal slicing results
- More economical for service and repairs with reduced parts and reduced service time

Sanitary Burnished Aluminum Base

Improved sanitation, labor savings

- One piece base protects against possible growth of bacteria
- No cracks/crevices or bolt holes where product can lodge and bacteria may grow
- Easy cleanup and durable finish

Double-Action Indexing Cam

Increases reliability, easier to use, increased yield

- The first full revolution of the indexing knob provides precise control for shaving, chipping and thin slicing

- The second revolution opens the gauge plate quickly for thicker slicing

- Gauge plate holds positionZ for consistent, precision slicing

Permanently Mounted Ring Guard

Protection

- Protects knife during operation and cleaning

Heavy Gauge Stainless Steel Top Cover with Integrated Product Deflector

Durability, ease of use, sanitation

- Twelve-gauge stainless steel maintains shape to ensure consistent fit
- Spring loaded knob for quick removal and easy cleanup
- One piece design for simplistic usage

Lift Lever

Improved sanitation, ease of use

- Props machine for easy cleaning underneath slicer

Removable Rear Deflector

Improved sanitation, ease of use

- Allows access for thorough cleaning
- No tools required means easy removal during cleaning

½ H.P. Knife Drive Motor

Durability, performance

- Reserve power runs at 400 rpm for optimum results

Nylon Carriage Roller

Performance

- Easy movement for manual operation

E-Nickel Plated Single Slide Rod with Reservoir Wick

Performance, durability, lower maintenance

- Smooth operation with continuous lubrication of carriage rod
- Resistant to rust

Stainless Steel Carriage and Knife Cover

Improved sanitation, durability

- Maximum sanitation with minimum cleanup time
- Corrosion resistant, impact resistant

Ergonomic Style Handle

Operator satisfaction

- Comfortable manual operation

Meat Grip Options

Multiple choices for improved yield and consistency

- Front meat grip standard
- Heavy front meat grip available

SPECIFICATIONS

MICROBAN® ANTIMICROBIAL PRODUCT

PROTECTION: The Microban additive is built into the external plastic components to inhibit the growth of bacteria, mold, mildew and fungi, keeping the slicer “cleaner between cleanings.” The additive is designed to last the life of the products in which it is incorporated and works continuously to maintain a lower level of odor and stain causing microorganisms.

TWO-SPEED AUTOMATIC CARRIAGE WITH

FRONT MOUNTED CONTROLS: Low Speed is 36 strokes per minute. 52 strokes per minute high speed for greater productivity. Carriage can be disengaged from power drive whether slicer is in operation or not. Automatic engagement and speed selector controls located in front of machine. Speed can be changed with slicer motor on or off. Carriage driven by DC gear-reduction motor and 4 bar synchronous linkage.

TILTING REMOVABLE CARRIAGE SYSTEM:

Positive angle carriage design enables operator to slice without manual feed. The stainless steel carriage system tilts back easily for midday cleaning and is removable for thorough cleaning and sanitation procedures. The carriage has 12½" manual travel.

CONTOURED CAST STAINLESS STEEL STAY

SHARP KNIFE: Hobart Stay Sharp, contoured cast solid stainless steel, 11¾" diameter with sanitary hub. Knife is protected by a permanently mounted ring guard with integrated product deflector. The stainless steel knife cover provides easy access for cleaning. Gauge plate protects knife edge when closed. Knife cover is quickly removed with a quarter turn of the spring loaded locking knob.

TOP MOUNTED BORAZON STONE SHARPENER:

One lever operation utilizing two Borazon stones to sharpen and hone in five seconds. Removable and top mounted. When sharpener is removed for cleaning, knife edge is shielded. Borazon stones have lifetime guarantee.

HOBART POLY V-BELT DRIVE SYSTEM: Knife is driven by a Hobart Poly V belt and runs at 400 rpm for optimal performance.

SANITARY BURNISHED ALUMINUM BASE:

One-piece base protects against possible growth of bacteria. All surfaces are durable and smooth, presenting no holes or crevices in which food can lodge.

DOUBLE-ACTION INDEXING CAM: First revolution of index cam for precision slicing; second revolution for thicker slicing selection. Indexing cam holds true to setting during slicing operation.

PERMANENTLY MOUNTED RING GUARD: Permanently mounted ring guard with integrated product deflector protects knife.

HEAVY GAUGE STAINLESS STEEL TOP COVER WITH INTEGRATED PRODUCT DEFLECTOR:

One piece design made of 12 gauge stainless steel, durable to maintain shape and ensure consistent fit. Spring loaded knob for quick removal and replacement.

LIFT LEVER: Lift lever facilitates raising slicer to tilted position for cleaning beneath the machine.

REMOVABLE REAR DEFLECTOR: No tools are required for removal of the deflector for thorough cleaning of the slicer.

KNIFE MOTOR: ½ H.P., permanently lubricated ball bearings. Single phase capacitor-start, induction run.

ELECTROLESS NICKEL PLATED SINGLE SLIDE ROD WITH RESERVOIR WICK: Transport slide rod is E-Nickel electroless plated. Slide rod bearings feature an oil reservoir/oil wick.

FINISH: Stainless steel carriage, gauge plate and knife cover. Burnished aluminum base.

ERGONOMIC STYLE HANDLE: Specially designed for ease of use during manual operation.

MEAT GRIP: Front mounted grip is high strength thermoplastic. Swings out of way when not in use.

ELECTRICAL SPECIFICATIONS: 120/60/1 and 240/60/1 (3 amps) – U L Listed. Also available in 100/50/60/1 and 230/50/1 (3 amps) – not submitted for U L Listing.

SWITCH: Moisture protected toggle type, operated by a push-pull rod.

CORD & PLUG: 6-foot, three-wire power supply cord and plug. Plug not furnished on export models.

CAPACITY: The carriage will take food up to 12" in width or 7½" in diameter.

GAUGE PLATE: Gauge plate is a heavy aluminum casting with ribbed laminated stainless steel face for smooth feeding. Adjustable to cut any thickness of slice up to 1".

WARRANTY: All parts and service coverage for one year including knife. Lifetime guarantee on Borazon stones in the sharpening system.

WEIGHTS FOR THE FOLLOWING ITEMS: Tubular Chute 9.1 lbs.; Swing Arm .61 lbs.; Heavy Front Meat Grip 2.76 lbs.; Heavy Handle 2.7 lbs.; Standard Meat Grip 2.34 lbs.

WEIGHT: Shipping 182 lbs., Net 140 lbs.

2712 SLICER



LISTED BY: UNDERWRITERS LABORATORIES INC AND NSF INTERNATIONAL.

DETAILS AND DIMENSIONS

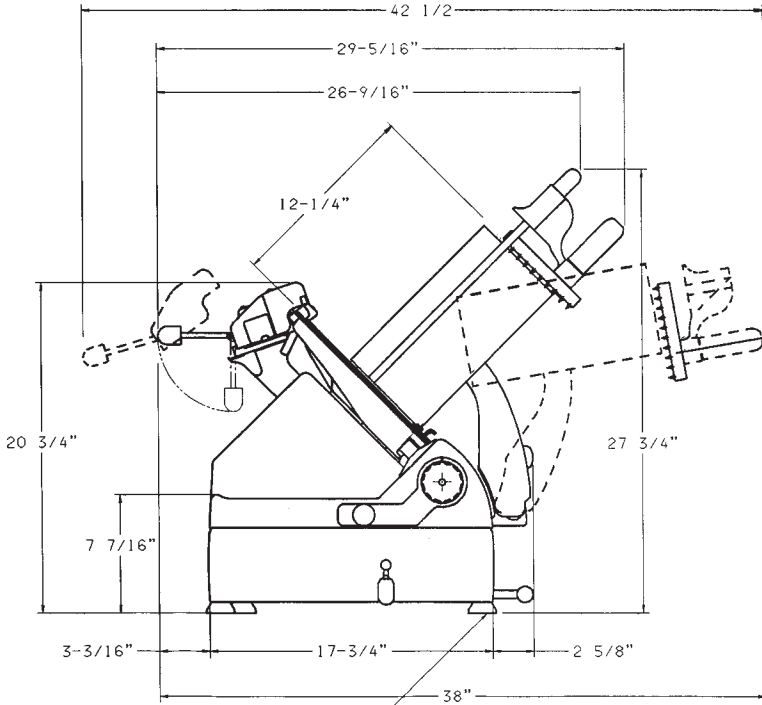

WHEN IN CLEANING POSITION
LEG 5" OFF GROUND
PIVOTED BY OTHER LEG

11-3/4"
KNIFE DIA.

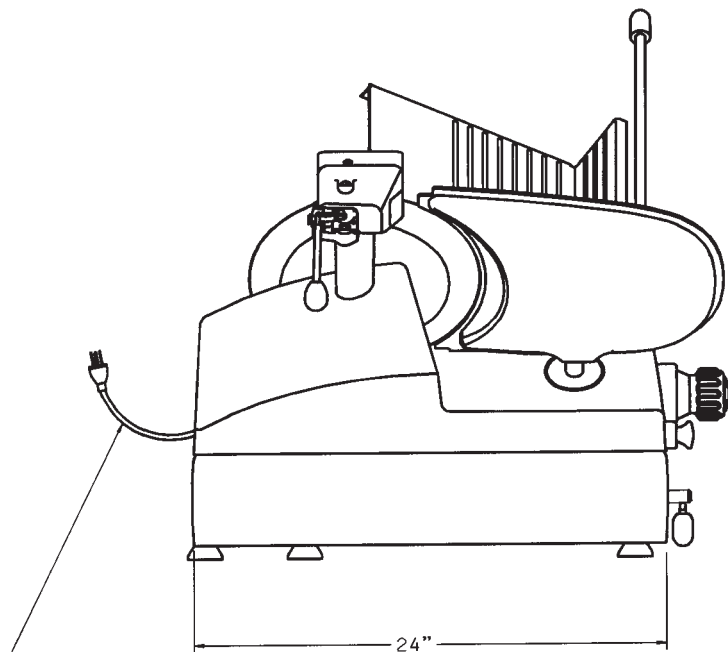

POWER CORD
APPROX 6 FT
LONG

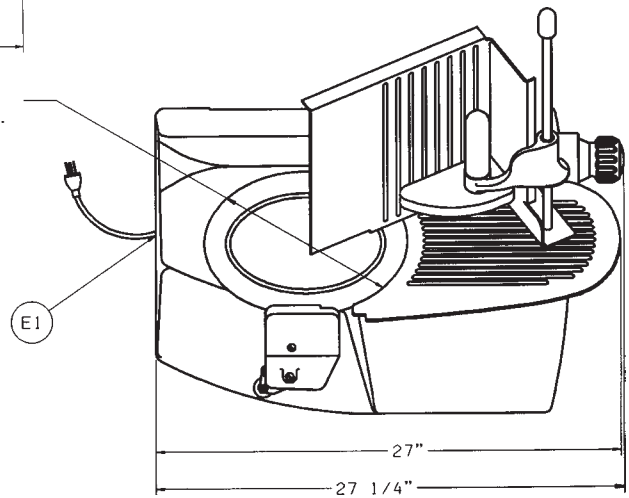

WARNING

ELECTRICAL AND GROUNDING CONNECTIONS
MUST COMPLY WITH THE APPLICABLE PORTIONS
OF THE NATIONAL ELECTRICAL CODE AND/OR
OTHER LOCAL ELECTRICAL CODES.

LEGEND

E1-ELECTRICAL CONNECTION,
APPROX 6 1/2" ABOVE
COUNTER TOP

Microban and the Microban symbol are registered trademarks of the Microban Products Company, Huntersville, NC.

As continued product improvement is a policy of Hobart, specifications are subject to change without notice.

701 S Ridge Avenue, Troy, OH 45374 • 937-332-3000 • 1-800-333-7447