



MODEL: C9797-K2PF

Kleensteam II (for Combi's with a Generator, models OEB & OGB):
(with Prefilter, two Carbon-Block Cartridges & one Scale Stick Cartridge)

Cleveland Standard Features :

Kleensteam II

- Recommended filter delivering high quality filtered water with scale inhibition
- System includes: one prefilter, two carbon-block cartridges and one scale stick cartridge.
- Dual cartridge design provides enhanced performance for low or high flow capacity steamers
- 2 five micron carbon block filters improve performance, maximize energy efficiency and increase the life of combi oven steamers
- Reduces chlorine-induced corrosion
- Long lasting SS-10 cartridge is more effective in higher alkalinity/hardness/TDS/temperature installations.
- Sophisticated Hydroblend compound prevents limescale formation in high temperature steam applications
- System is simple to install, operate and maintain

Prefilter:

- Filters out larger dirt and rust particles
- Extends the life of primary filter cartridges
- Tightly spun EC210 sediment cartridge delivers 10 micron nominal filtration
- Durable slim bowl design makes cartridge change outs easy to handle
- Clear housing allows for visually inspection of trapped particles and makes determining when to change the cartridge easy

Options and Accessories

- Replacement Cartridges

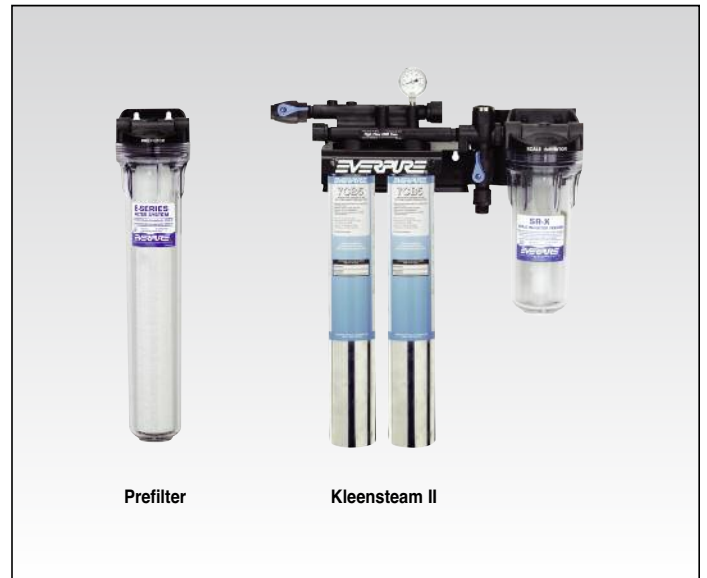

Prefilter

Kleensteam II

Short Form Specifications

Shall be Cleveland Model C9797-K2PF Kleensteam II with one prefilter, two carbon-block cartridges and one scale stick cartridge, dual cartridge design for Combi's with a Generator, models OEB & OGB, 2 five micron carbon block filters and SS-10 cartridge for higher alkalinity / hardness / TDS / temperature installations.

Kleensteam II (for Combi's with a Generator, models OEB & OGB):
 (with Prefilter, two Carbon-Block Cartridges & one Scale Stick Cartridge)

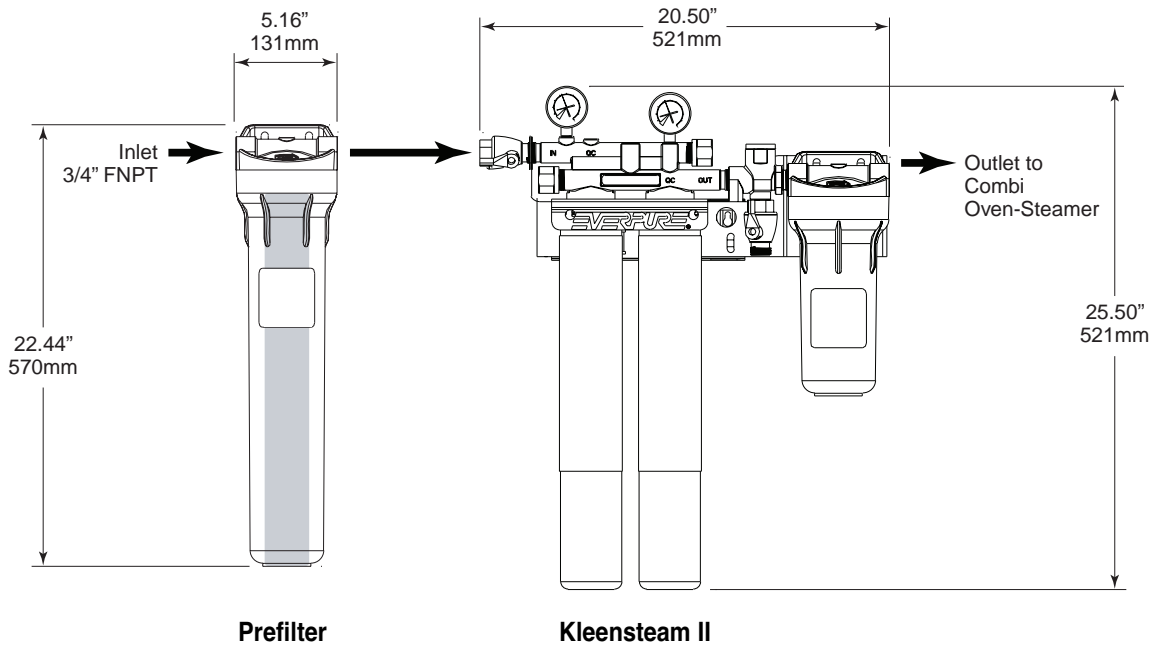

Technical Data

Overall Dimensions:	25.50"H x 20.50"W x 7.00"D
Inlet Connection:	3/4" FNPT
Outlet Connection:	3/4" FNPT
Service Flow Rate:	Maximum 3.5 gpm (13.2 Lpm) - twin cartridges
Pressure Requirements:	10 - 125 psi (0.7 – 8.6 bar), non-shock
Maximum Water Temperature at Inlet:	100°F (38°C)
Alkalinity Range:	2 to 12 grains per gallon
Electrical:	No electrical connection required
Shipping Weight:	34 lbs.
Operating Weight:	42 lbs.

The contaminants or other substances removed or reduced by this drinking water system are not necessarily in your water. Do not use with water that is microbiologically unsafe or of unknown quality without adequate disinfection before or after the system. Systems certified for cyst reduction may be used with disinfected water that may contain filterable cysts.

NSF Certified under NSF/ANSI Standard 42 for materials

NOTES:
 Cleveland Range reserves right of design improvement or modification, as warranted.
 Many regional, state and local codes exist and it is the responsibility of the owner and installer to comply with the codes.
 Cleveland Range equipment is built to comply with applicable standards for manufacturers.



MODEL: C9797-40

Kleensteam II (for Boilerless Combi's models OES & OGS):
 with two Carbon-Block Cartridges (Prefilter not included)

Cleveland Standard Features :

Kleensteam II

- Recommended filter delivering high quality filtered water with scale inhibition
- System includes: two carbon-block cartridges.
- Dual cartridge design provides enhanced performance for low or high flow capacity steamers
- 2 five micron carbon block filters improve performance, maximize energy efficiency and increase the life of combi oven steamers
- Reduces chlorine-induced corrosion
- Sophisticated Hydroblend compound prevents limescale formation in high temperature steam applications
- System is simple to install, operate and maintain

Options and Accessories

- Prefilter, filters out larger dirt and rust particles (20" clear housing)
- Replacement Cartridges



Kleensteam II

Short Form Specifications

Shall be Cleveland Model C9797-40 Kleensteam II with two carbon-block cartridges, dual cartridge design for Boilerless Combi's models OEB & OGB.

Kleensteam II (for Boilerless Combi's models OES & OGS):
with two Carbon-Block Cartridges (Prefilter not included)

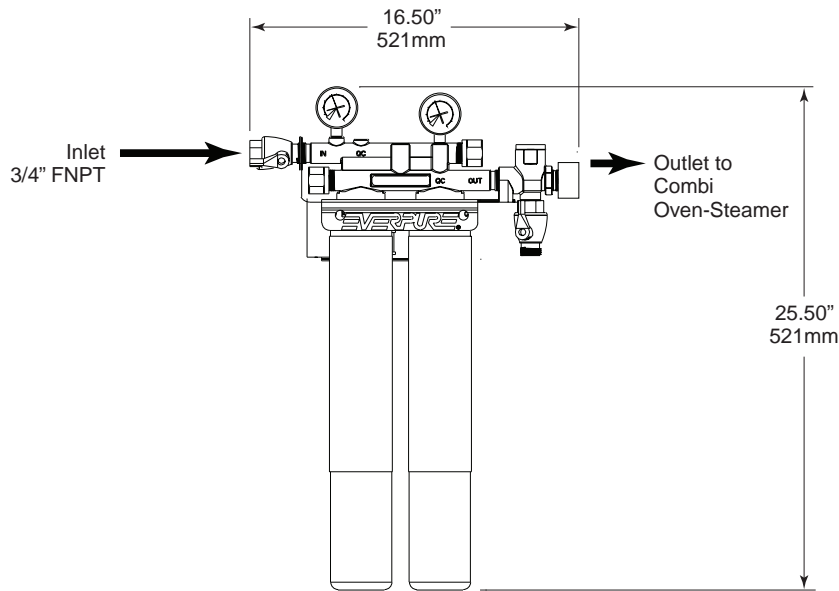

Kleensteam II

Technical Data

Overall Dimensions:	25.50"H x 16.50"W x 7.00"D
Inlet Connection:	3/4" FNPT
Outlet Connection:	3/4" FNPT
Service Flow Rate:	Maximum 3.5 gpm (13.2 Lpm) - twin cartridges
Pressure Requirements:	10 - 125 psi (0.7 – 8.6 bar), non-shock
Maximum Water Temperature at Inlet:	100°F (38°C)
Alkalinity Range:	2 to 12 grains per gallon
Electrical:	No electrical connection required
Shipping Weight:	27 lbs.
Operating Weight:	32 lbs.

The contaminants or other substances removed or reduced by this drinking water system are not necessarily in your water. Do not use with water that is microbiologically unsafe or of unknown quality without adequate disinfection before or after the system. Systems certified for cyst reduction may be used with disinfected water that may contain filterable cysts.

NSF Certified under NSF/ANSI Standard 42 for materials

NOTES:

Cleveland Range reserves right of design improvement or modification, as warranted. Many regional, state and local codes exist and it is the responsibility of the owner and installer to comply with the codes. Cleveland Range equipment is built to comply with applicable standards for manufacturers.