



*Model MCO-GS-10-S*

### Specifications:

Garland Master Full-Size Standard Depth Single or Double (MCO-GS-10/20-S) or Deep Depth Single or Double (MCO-GD-10/20-S) gas convection oven. 60,000 BTU (17.6 kW)/cavity, 3/4 HP fan motor with two speed fan control. Mechanical electronic spark ignition. Natural or propane gas. Master 200 control. Porcelain enameled oven interior with coved corners, Six (6) oven racks and 13-position rack guides. Interior measures 29" (736mm) wide by 24" (610mm) high by 24" (610mm) deep for standard depth and 29" (736mm) wide by 24" (610mm) high by 28" (610mm) deep for deep depth. Stainless steel front, sides, top and legs. 60/40 dependent door design with double pane thermal window in both doors and interior lighting. Specify voltage if other than 115 volt, 60 Hz, 1 phase. UL, CUL Classified and NSF Listed.

### Standard Features:

- Master 200 Mechanical Control with 150°F(66°C) to 500°F(250°C) temperature range and mechanical timer.
- Electronic spark ignition, including automatic pilot system with 100% safety shut off.
- Two speed fan control (high and low) with 3/4 HP fan motor.
- Total of 60,000 BTU (17.6 kW) loading per oven cavity.
- Natural or propane gas.
- Stainless steel front, sides, top and legs.
- 60/40 dependent door design with double pane thermal window in both doors and interior lighting.
- Porcelain enameled oven interior with coved corners.
- Six (6) chrome plated ovens racks on 13-position rack guides.
- Service accessibility from the front.
- Double deck models available.
- One year limited parts and labor warranty (USA and Canada only).
- Five year limited door warranty, excluding window (USA and Canada only)

### Optional Features (additional charge):

- ☐ 80,000 BTU (23.4kW) burner package
- ☐ Stainless steel solid doors.
- ☐ Stainless steel doors w/window in left door only.
- ☐ Black powder coat epoxy sides, top and legs.
- ☐ Continuous clean oven interior.
- ☐ Stainless steel oven interior.
- ☐ Extra oven racks.
- ☐ Swivel casters, (4) w/ front brakes.
- ☐ Low profile casters, (4) w/ front brakes (double ovens only).
- ☐ Open base with rack guides and shelf (black powder coat epoxy or stainless steel).
- ☐ Canopy diverter (black powder coat epoxy or stainless steel).
- ☐ Direct connect vent.
- ☐ Mobile cart loading system with basket dollies (deep depth oven only).
- ☐ Back enclosure (black powder coat epoxy or stainless steel).
- ☐ 3/4" gas flex hose and quick disconnect.
- ☐ 208 or 240 volt, single phase (please specify).
- ☐ Extended second year limited warranty (USA Only)



For USA, Contact:  
 Garland Commercial Industries,  
 Tel: 570-636-1000  
 Fax: 570-636-3903

For United Kingdom & Ireland, Contact:  
 Enodis, UK, Ltd.  
 Tel: 0181-561-0433  
 Fax: 0181-848-0041

For Canada & the Rest of the World, Contact:  
 Garland Commercial Ranges, Ltd.  
 Tel: 905-624-0260  
 Fax: 905-624-5669



Item #: \_\_\_\_\_  
 Model #'s: MCO-GS-10/20-S, MCO-GD-10/20-S  
 Product Name: Master Convection Oven

Model # 's MCO-GS/GD-10/20-S

Master Convection Oven

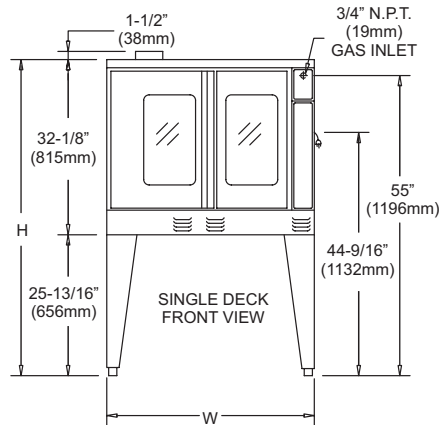
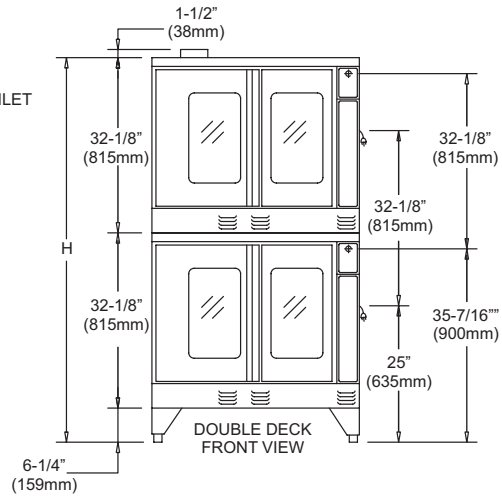
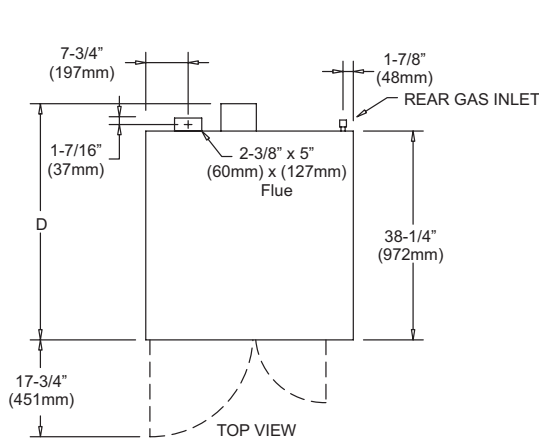

Installation Notes:  
 Non-Combustible and Combustible Wall Clearances  
 Sides: 1" (25mm)  
 Back: 3" (76mm)  
 Entry Clearance:  
 Crated: 44 1/2" (1130mm)  
 Uncrated: 32 1/2" (826mm)

Manifold Pressure:  
 Natural: 4.5" WC (11 mbar)  
 Propane: 10" WC (25 mbar)  
 Max 13.8" WC @ 70°F  
 NOTE: Data applies only to North America.

SINGLE-DECK MODELS	INTERIOR DIMENSIONS			EXTERIOR DIMENSIONS			SHIP WT. Lbs./kg	SHIP DIM. Cubic Ft.
	W	H	D	W	H	D		
Standard Depth	29" (736mm)	24" (610mm)	24" (610mm)	38" (965mm)	57 1/2" (1461mm)	39 1/4" (997mm)	510/232	42
Deep Depth	29" (736mm)	24" (610mm)	28" (711mm)	38" (965mm)	57 1/2" (1461mm)	43 1/4" (1099mm)	510/232	42

DOUBLE-DECK MODELS	INTERIOR DIMENSIONS			EXTERIOR DIMENSIONS			SHIP WT. Lbs./kg	SHIP DIM. Cubic Ft.
	W	H	D	W	H	D		
Standard Depth	29" (736mm)	24" (610mm)	24" (610mm)	38" (965mm)	70 1/2" (1791mm)	39 1/4" (997mm)	1024/464	84
Deep Depth	29" (736mm)	24" (610mm)	28" (711mm)	38" (965mm)	70 1/2" (1791mm)	43 1/4" (1099mm)	1024/464	84

MODELS	INPUT RATINGS, NAT & PRO			ELECTRICAL SPECIFICATIONS		
	BTU/hr	KW Eqiv.	Gas Inlet	120V/1Ph.	240V/1Ph.	Int'l.
Single Deck	60,000	17.6	(1) @ 3/4" NPT	(1) @ 9.4A	(1) @ 5.2A	Contact Canadian Operation
Double Deck	120,000	35.2	(1) @ 1" NPT	(2) @ 9.4A	(2) @ 5.2A	

- Notes:
- Standard electrical specifications include motor requirements.
  - (120V units) 115V, 3/4 HP, 2-speed motor; 1140 and 1725 rpm, 60Hz
  - (240V units) 200-240V, 3/4 HP, 2-speed motor; 1140 and 1725 rpm, 60/50Hz
  - A 6 ft. line cord is provided for each 120V deck with a (NEMA #5-15P) plug.
  - Garland recommends a separate 15 AMP circuit for each 120V unit.

Gas Input Ratings shown here are for installations up to 2,000 ft. (610m) above sea level. Specify altitudes over 2,000 ft.

Commercial cooking equipment requires an adequate ventilation system. For additional information, refer to the National Fire Protection Association's standard NFPA96, "Vapor Removal from Cooking Equipment." (NOTE: For North America only)

Please specify gas type when ordering.

Continuous product improvement is a Garland policy. Specifications and designs are subject to change without notice.

