

GDC Series

Glass Door Merchandisers

The GDC Series of merchandising refrigerators and freezers provides unlimited merchandising opportunities that boost impulse sales. Self closing, anti-fogging glass doors and high density polyurethane insulation are just a few of the features that make the GDC Series the best value on the market.



- Foamed-in-place high density polyurethane cell insulation
- ETL Safety & Sanitation Approved
- Anti-fogging, self-closing glass doors



This Avantco SC-80 countertop display refrigerator with glass door is the perfect way to increase impulse sales at your convenience store, market, or deli. The Avantco SC-80 merchandiser's clear glass door draws attention to tempting grab and go items like canned or bottled drinks, pre-wrapped sandwiches, or take out items like prepackaged salads. It has a temperature range of 34 to 45 degrees Fahrenheit.

Interior lighting and a lighted sign allow you to further advertise all of your tempting treats. Three adjustable, plastic coated shelves are included to give you complete control over the merchandiser's shelving configuration and accommodate a variety of different sized products.

The Avantco SC-80 merchandiser's top mounted, 1/10 hp compressor uses R134a refrigerant. Foamed in place polyurethane cell insulation helps maintain interior temperatures, while its cooling fan circulates air quickly throughout the merchandiser to regulate the internal temperature even when the refrigerator's self closing door is opened.

The Avantco SC-80 countertop display refrigerator with glass door has a 110-120V, 60 Hz. electrical rating, and is ETL Listed. A NEMA 5-15P plug and 5' 6" cord are included.

Features

- Self closing door
- 3 plastic coated steel shelves included
- Interior lighting and lighted sign
- Foamed in place polyurethane insulation
- Automatic defrosting
- Available in black
- ETL & ETL Sanitation Listed

Technical Data

Dimensions

| | |
|---------------------------------|-----------------------------|
| Exterior Dimensions (W x D x H) | 18 1/4" x 18 1/2" x 37" |
| Interior Dimensions (W x D x H) | 12 1/2" x 12 1/2" x 25 1/2" |
| Net Volume (cu. ft.) | 2.7 |
| Net Weight | 62 |

Cooling

| | |
|------------------------------------|------------|
| Temperature Range | 34° - 45° |
| Refrigerant | R134a |
| Maximum Ambient Temperature Rating | 90° |
| Defrosting | Automatic |
| Temperature Display | No |
| Temperature Controller | Mechanical |
| Horsepower | 1/10 |

Construction

| | |
|---------------------|--|
| Housing Material | Rust-proof, black plastic superstructure |
| Door/Lid Material | Glass Door |
| Insulation Material | Foamed in Place Polyurethane |
| Shelf Material | Plastic Coated Steel |

Electrical

| | |
|------------------------|---------|
| Voltage | 110-120 |
| Amps | 1.6 |
| Hz | 60 |
| Phase | 1 |
| Electrical Cord Length | 66" |

Plan View

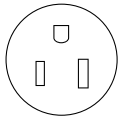
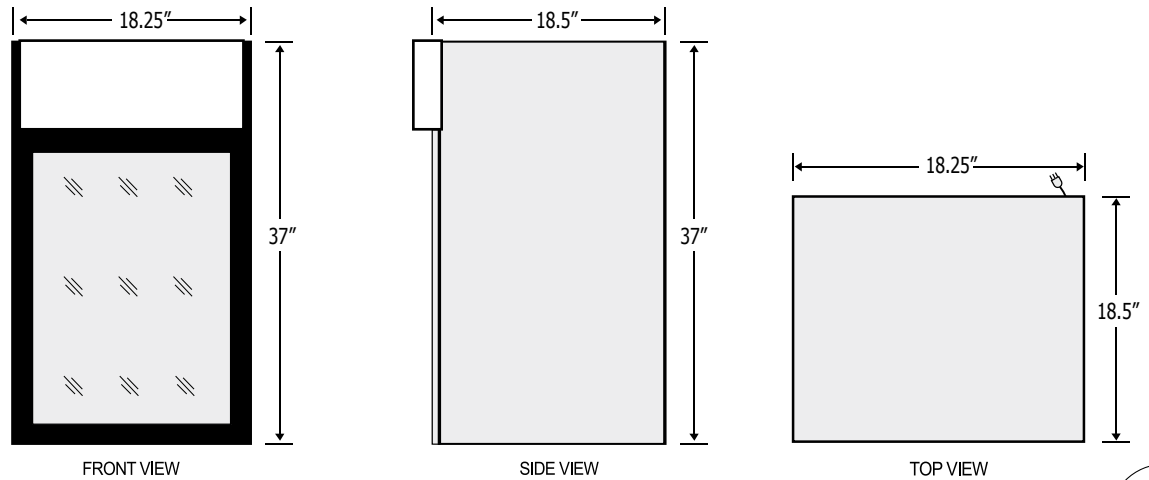

NEMA 5-15P



1 year
WARRANTY

Parts & Labor



5 year
WARRANTY

Compressor

All Avantco Refrigerators and Freezers are backed by a 1 year parts and labor warranty, with a 5 year warranty on the compressor. For warranty inquiries or service, first locate the serial number plate on the front of the unit, or inside the door jamb. Next, call 1-800-678-5517. Be sure to have the serial and model numbers available when contacting service technicians.