

---

# DS

---

Double Stack Freezer  
Merchandiser



**DS** 48

(Shown w/ optional graphics  
& optional light bar)



---

Profit from the Power of Partnership.

---

800.441.4014

[www.excellenceindustries.com](http://www.excellenceindustries.com)

# DS Double Stack Freezer Merchandiser



**DS<sub>30</sub>**  
(Shown with optional graphics)



**DS<sub>48</sub>**  
(Shown with optional light bar)

## Technical Summary

Model	Size					Electrical			Refrigeration		Other		
	Dimensions (inches) Length x Depth x Height	Cubic Feet (Top/Bottom)	Cubic Feet	Net Weight (lbs.)	Shipping Weight (lbs.)	Voltage/Hz/Phase	Running Amps	KWh/24hr	Compressor HP	Refrigerant	Temperature	No. of Baskets	Container Quantity
DS-30	30 3/4 x 31 x 47 3/4	4.9/5.0	9.9	198	260	115/60/1	6.2	5.3	1/4+1/4	R-134a	0° to -13°F	3+3	52
DS-48	47 3/4 x 31 x 47 3/4	7.8/8.1	15.9	266	345	115/60/1	7.6	6.5	2/5+2/5	R-134a	0° to -13°F	5+5	44

-Add approx. 10" for light bar      - Add 2" for rear spacer

### SPECIAL FEATURES

- Internal LED lighting
- Casters standard, front locking
- White interior
- Baskets include 2 dividers each
  - DS-48 - Top - 5 each w/ 2 dividers
  - Bottom - 5 each w/ 2 dividers
  - DS-30 - Top - 3 each w/ 2 dividers
  - Bottom - 3 each w/ 2 dividers
- Optional light bar
- Optional lock & key
- Optional flat shelves
- Optional graphics: Frozen Treats or Frozen Foods or custom

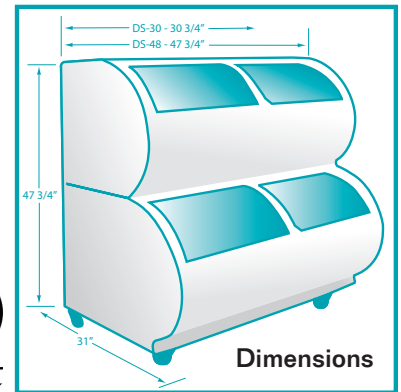

Profit from the Power of Partnership.

Excellence Industries is a division of Stajac Industries, Inc. The company reserves the right to change the design and/or specifications of these products without notice. Printed in the U.S.A. (4/15)

Innovation  
Logistics  
Distribution  
Leasing  
Service  
Refurbishing  
Recycling

3710 Corporex Park Drive, Ste. 100 | Tampa, FL 33619 | 800.441.4014

www.excellenceindustries.com