



Salamander Broiler



CPG-SB-36
351S36CPG

Salamanders feature a stainless steel top, front, and sides, cool to the touch knobs, and one-piece broiler grid. Salamanders are chrome-plated and made of heavy bar stock. Rack assembly rolls out adequately for loading and unloading and for easy cleaning.

Adjustable broiler rack has spring balanced, adjustable tension assembly that raises and lowers with positive multi-position locking. Equipped with gas-fired 35,000 BTU atmospheric infrared burner. Adjustable gas valve and continuous pilot.

Full width, large capacity broiler pan removes for cleaning.

Can be mounted on all CPG restaurant ranges using optional heavy-duty reinforcement channels that fit existing back guards. Can be wall mounted with optional wall mounting bracket or used on a countertop with optional 4" legs.

Options include heavy duty reinforcement channels for range mount; 4" legs for counter mounting; wall mounting bracket for wall mounting. Extra rack. Also available with stainless steel bottom and back.

Standard Features

- One 35,000 BTU atmospheric burner for precise, instant, even heating
- Heavy gauge steel construction
- Stainless steel top, side panels and front
- Recessed control valve for easy access and serviceability
- Removable heavy-gauge grid carriage with chrome-plated wire rack with multiple cooking positions
- Constant pilot for instant ignition
- Available as a wall, counter or range mount

Specifications

- Stainless steel top, front, and sides
- Welded and finished stainless steel seams
- One-piece broiler grid; chrome plated and made of heavy bar stock
- Removable 12 3/4"D x 28"W rack assembly
- Adjustable, spring balanced rack
- 35,000 BTU atmospheric infrared burner
- Adjustable gas valve and continuous pilot
- Full width broiler pan
- One year parts and labor warranty

Applications

Finishing steaks, browning chicken, cooking fish products, re-therming foods, cooking vegetables

Certifications





Salamander Broiler

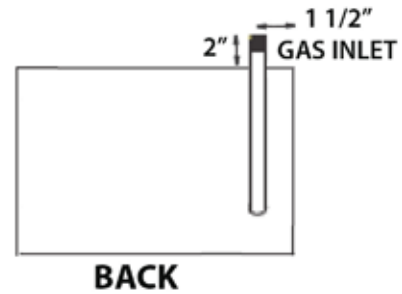
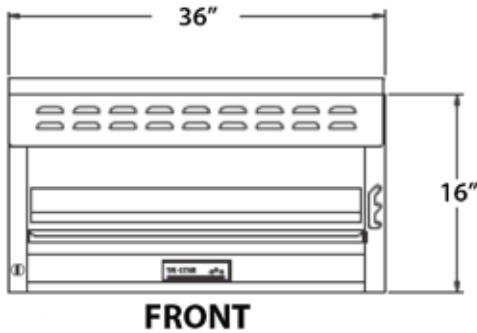
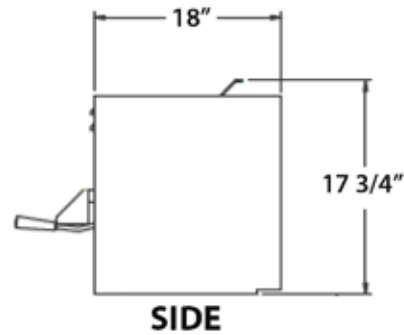
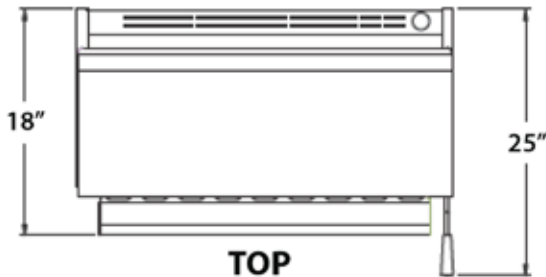

PRODUCT SPECIFICATIONS

Clearance:

Provide 0" clearance from non-combustible surfaces and 4" from back, 10" from sides from combustible surfaces.

Freight Class: 85

Gas Information:

Manifold pressure is 5.0"W.C. for natural gas or 10.0" for propane gas. Manifold size is 3/4" NPT. 3/4" pressure regulator supplied with equipment to be installed at time of connection. Must be ordered in either natural or L.P. gas.

CPGSB-36: 35,000 BTU

CPGSB-36: 220 Lbs

