



Hot Plates - Step Up

CPG step up hot plates feature heavy-duty back burners that are raised 4" above the front burners for safe and simple accessibility. They provide as standard many of the optional upgrades normally offered at a premium on other hot plate lines. CPG hot plates feature a stainless steel front, sides and landing ledge.

Models ranging from two to six open burners are available. The lift-off burner heads simplify cleaning and the 30,000 BTU/hr. burner output provides high performance cooking. The heavy-duty cast iron grates are designed in 12" x 12" sections to be removed easily and safely. Cast-in bowls direct heat upwards. For quick clean-ups a full width, removable drip pan is standard on all hot plate models.

Constructed for durability, CPG hot plates are made of heavy gauge steel with an angle iron chassis. The sides have inside liners for better insulation and increased strength.

Standard Features:

- 30,000 BTU/hr, lift-off burner heads for performance cooking and easy cleaning
- All burners are equipped with continuous pilots for instant ignition
- 12" x 12" heavy cast-iron section top-grates remove easily and accommodate a full range of cooking utensils for maximum versatility
- Anti-clogging pilot shield design engineered into the grate
- Back burners are raised 4" for safe and simple accessibility
- Stainless steel front, sides and landing ledge
- 3" stainless steel landing ledge provides a functional working area
- Available in 2, 4 and 6 burner models
- Cool to the touch knobs
- Shipped with L.P. orifice kit for field conversion
- One year parts and labor warranty



4 Burner
CPG-HP-4-24S-SU

Options & Accessories:

- Stainless steel stands
- Casters (front two are locking)
- Quick disconnect and flexible gas hose

Certifications





Hot Plates - Step Up

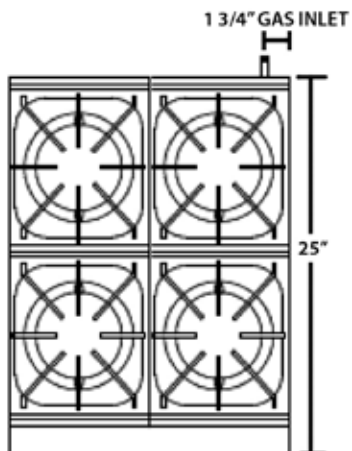

PRODUCT SPECIFICATIONS

Construction:

Heavy gauge steel construction. Stainless front, sides and landing ledge.

Gas:

Manifold pressure 5.0" W.C. natural gas. 10.0" W.C. propane gas. Manifold size 3/4"
Shipped with orifice kit for field conversion.

CPG-HP-2-12C-SU: 12"W, 2 Burners, 60,000 BTU

CPG-HP-4-24C-SU: 24"W, 4 Burners, 120,000 BTU

CPG-HP-6-36C-SU: 36"W, 6 Burners, 180,000 BTU

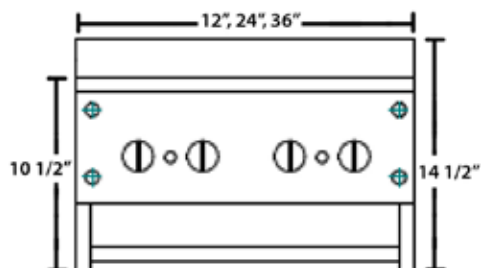

Weight:

CPG-HP-2-12C-SU: 85 Lbs

CPG-HP-4-24C-SU: 150 Lbs

CPG-HP-6-36C-SU: 220 Lbs

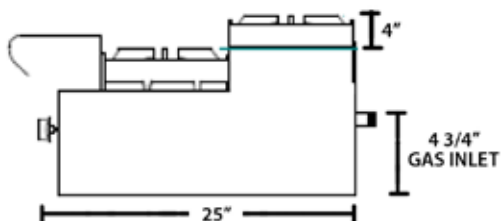

Freight Class: 85

