



PROJECT	
ITEM #	
QUANTITY	DATE
APPROVAL	

4460N/D4460N

Front-Breathing Self-Contained Compact Salad Top Refrigerators

Short Form Specifications

Exterior top is one-piece 22-gauge stainless steel with integral 2.12" (5.1cm) square nosing at the front. Top has openings to accept 8" or 12 1/6"-size 4"- 6" (10.2cm - 15.2cm) deep plastic pans. Adapter bars and 1/6 pans are supplied by Delfield. Temperature in top opening to maintain 33°F (1°C) to 41°F (5°C), with pans recessed 2.5" (6.4cm) at 86°F ambient room temperature, meeting NSF 7 requirements. One 60" x 10" x .5" (152cm x 25.4cm x 1.3cm) plastic cutting board is mounted on the top at the front edge.

Exterior back and bottom are two-piece 24-gauge galvanized steel. Exterior ends are stainless steel.

Interior sides are thermoformed ABS plastic with shelf supports. Base is fully insulated with high-density foamed in place polyurethane.

Refrigeration system uses HFC-404A refrigerant. Compressor is 1/2 H.P., with condenser coil and condensate evaporator mounted on rear of the cabinet. Evaporator coils and temperature control are located on the interior rear wall of the cabinet. Refrigerant flow is controlled by a capillary tube. Cabinet maintains an interior cabinet temperature of 36°F to 40°F (2°C to 4°C).

Electrical connections are 115 volt, 60 Hertz, single phase. Unit has an 8' (2.4m) long electrical cord and NEMA 5-15P plug.

Casters: Equipment is mounted on 2" (5.08cm) diameter casters, with front three locking. Equipment clearance above the floor is 2.5" (6.35cm).

The following applies to two door models only

Doors have a 22-gauge stainless steel exterior, with thermoformed ABS plastic interior liner. Cabinet has one adjustable epoxy-coated wire shelf per door opening.

The following applies to four drawer models only

Drawer fronts have a 22-gauge stainless steel exterior, with thermoformed ABS plastic interior liner. Drawer frames and slides are 14-gauge stainless steel, with stainless steel bearings. Each section has two drawers. Each top drawer holds one full size 12" x 20" (30.5cm x 50.8cm) pan 4"- 6" (10.6cm - 15.2cm) deep. Each bottom drawer holds one 12" x 20" (30.5cm x 50.8cm) pan 4" (10.6cm) deep. Pans supplied by others.

Optional Accessories and Modifications

- Flat lift off covers
 - 4" x 2" stainless steel backsplash
 - 18" wide single tier overshelf
 - Stainless steel back
 - Plastic laminate on front
 - Additional wire shelves
 - Door lock
 - *220V/50 Hertz electrical system
- *Inclusion of this option will alter electrical specifications of the unit.

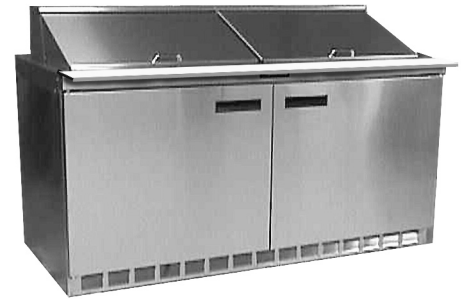

Model 4460N-12



Designs included in this equipment may be covered under one of the following patents: (5,461,878) (5,532,456) (5,282,367) (5,363,672)

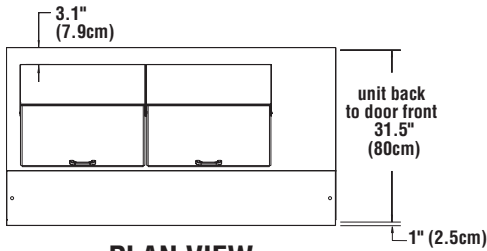

**PLAN VIEW
ALL MODELS**

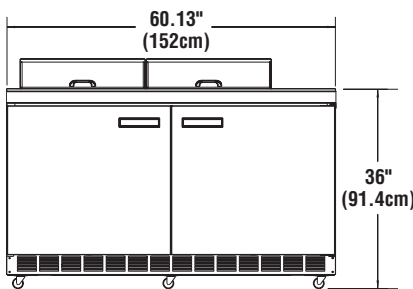

**ELEVATION VIEW
ALL DOOR MODELS**

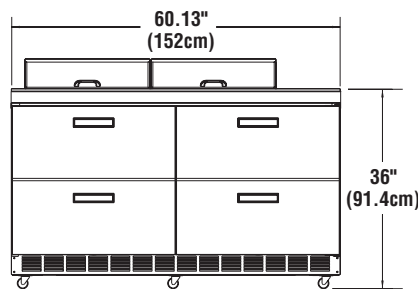

**ELEVATION VIEW
ALL DRAWER MODELS**

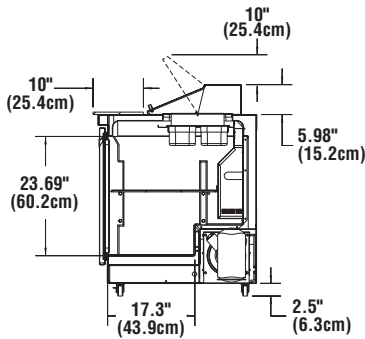

**END VIEW
ALL DOOR MODELS**

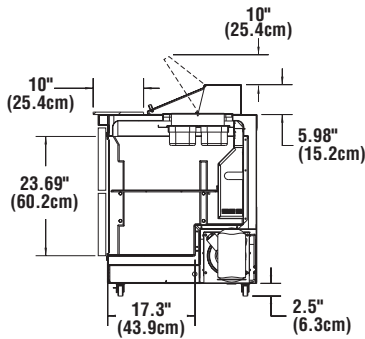

**END VIEW
ALL DRAWER MODELS**

1/6 SIZE PAN CONFIGURATIONS

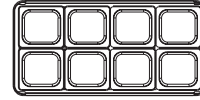

4460N-8/D4460N-8

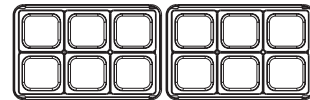

4460N-12/D4460N-12

DRAWER CLEARANCE IS: 22.5" (57cm)
DOOR CLEARANCE IS: 30" (76cm)

INSTALLATION NOTE:

Refrigeration system is designed so that air will flow under the unit, through the compressor area and out the front of the unit. Any restriction to this air flow path will void the warranties.

Mechanical Data—Standard Unit

MODEL NUMBER	1/6 SIZE PAN CAPACITY	#OF SHELVES	SHELF AREA. SQ. FT.	STORAGE CAP. CU. FT.	H.P.	VOLTS/HERTZ/ PHASE	AMPS	NEMA PLUG	SHIP WEIGHT
4460N-8	8	2	7.36	15.7	1/2	115/60/1	12.0	5-15P	345 lbs/ 156 kg
D4460N-8	8	N/A	N/A	2.7	1/2	115/60/1	12.0	5-15P	450 lbs/ 204 kg
4460N-12	12	2	7.36	15.7	1/2	115/60/1	12.0	5-15P	345 lbs/ 156 kg
D4460N-12	12	N/A	N/A	2.7	1/2	115/60/1	12.0	5-15P	450 lbs/ 204 kg