

# Symphony™ countertop and wall mount ice and water dispensers with Maestro™ Chewblet® ice icemaker

50 Series

## Countertop models with (A) air- or (W) water-cooled icemaker

- 50CT400A/W – 115V, 60Hz, integral icemaker
- 50CR400A/W – 115V, 60Hz, Satellite-fill icemaker
- C50CT400A/W – 220V, 60Hz, integral icemaker
- C50CR400A/W – 220V, 60Hz, Satellite-fill icemaker
- E50CT400A/W – 230V, 50Hz, integral icemaker
- E50CR400A/W – 230V, 50Hz, Satellite-fill icemaker

## Wall mount models with (A) air- or (W) water-cooled icemaker

- 50HT400A/W – 115V, 60Hz, integral icemaker
- 50HR400A/W – 115V, 60Hz, Satellite-fill icemaker
- C50HT400A/W – 220V, 60Hz, integral icemaker
- C50HR400A/W – 220V, 60Hz, Satellite-fill icemaker
- E50HT400A/W – 230V, 50Hz, integral icemaker
- E50HR400A/W – 230V, 50Hz, Satellite-fill icemaker



Countertop model shown with SensorSAFE accessory

*Symphony™*

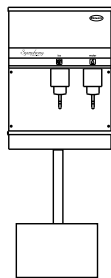

Countertop model with Satellite-fill icemaker

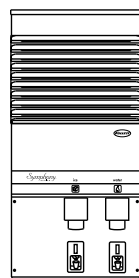

Wall mount model with integral icemaker\*

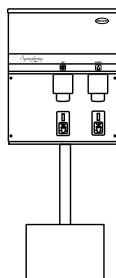

Wall mount model with Satellite-fill icemaker\*

Countertop and wall mount ice and water dispensers with air- or water-cooled icemaker. Stainless steel frame and exterior with plastic trim. Up to 50 lbs (23kg) storage. Produces approximately 400 lbs (181kg) of Chewblet compressed nugget ice in a 24-hour period.

### Convenient, sanitary, user-friendly dispensing

- Labor-saving, sanitary automatic load
- Lever dispensing standard
- Quick shut-off reduces the amount of wasted ice
- High-quality Chewblet compressed nugget ice is slow melting, easy to chew
- Clear chute focuses ice cleanly into cups, pitchers, carafes, ice bags

### SensorSAFE™ accessory offers even more sanitation and convenience

- Infrared sensing eliminates container to dispenser contact, reduces chance of cross-contamination
- Easy, one-hand filling of containers

### Space-saving, attractive design

- 21" (534mm) width requires less space than other models of similar capacity
- Side clearance not required for ventilation
- Softly-rounded European styling
- High-quality stainless steel exterior with plastic trim

### Environmentally-friendly Maestro icemakers

- State-of-the-art R404A icemaker automatically loads dispenser with 400 lbs (181kg) of ice each day
- Stainless steel evaporator and auger
- Energy-efficient; no costly defrost cycles or high waste water
- Quiet production; no noisy harvest cycles
- Satellite-fill™ icemakers can be located up to 20 feet (6m) from dispenser; remove heat, noise and bulk from customer area

### Accessories

- SensorSAFE actuation (standard on wall mount models)
- Chilled water option (item# AFH20CHIL2550)
- Water filter kit (item# 00130229)
- Base stand (for models 50CT400A/W, C/E50CT400A/W) (item# AF50BASESTD)
- SafeCLEAN™ environmentally-responsible ice machine cleaner (item# 00132001)
- Slide-out track for Satellite-fill icemakers (item# AFGSLIDER400A (air-cooled icemakers) and item# AFGSLIDER400W (water-cooled icemakers))
- Drain pan assembly for wall mount models (item# AFH50WBASE)

\* Standard without drain pan. Drain pan available – contact factory.

# 50 Series

# Symphony™ countertop and wall mount ice and water dispensers with Maestro™ Chewblet® ice icemaker

## Models with Satellite-fill Icemaker

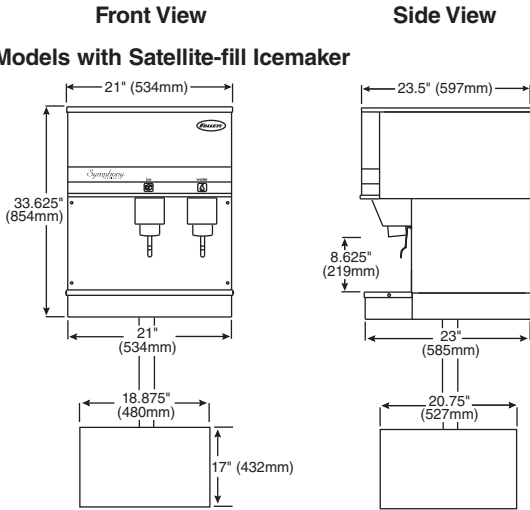

## Models with Integral Icemaker

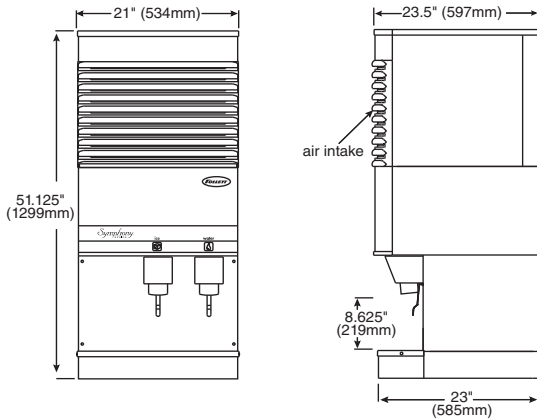

### Wall Mount Models

- Deduct 3.625" (92mm) from height and add .5" (13mm) to depth shown
- Wall mount bracket and SensorSAFE standard
- Standard without drain pan. Drain pan available – contact factory.

### Connections

- Countertop models: utilities connect through back or bottom. Back entry shown.
- Wall mount models: utilities connect through back
- Supplied 2" (51mm) duct and louver must be installed for undercounter Satellite-fill icemaker installations

### Clearances

	Models with integral icemaker		Models with Satellite-fill icemaker	
	Air-cooled	Water-cooled	Air-cooled	Water-cooled
<b>Required for ventilation</b>	6" (153mm) top	N/A	6" (153mm) right side of icemaker	N/A
<b>Recommended for service</b>	12" (305mm) top	12" (305mm) top	12" (305mm) top of icemaker; 12" (305mm) top of dispenser	12" (305mm) top of icemaker; 12" (305mm) top of dispenser

See Dispenser Detail Sheet, form# 2075, for important installation information

**Standard Electrical** – 115V, 60Hz, 1 phase, 13 amps, max. fuse 20 amps. 7 ft (2.1m) cord and NEMA 5-20 hospital-grade plug provided with each dispenser. If local code requires hard-wiring, separate disconnects also required.

**Alternate Electrical** – 220V, 60Hz, 1 phase, 6.5 amps. 230V, 50Hz, 1 phase, 6.5 amps. Cord only. Wire in accordance with all local codes.

### Approximate Shipping Weight

C/E/50CT400A/W – 295 lbs (134kg)  
C/E/50CR400A/W – 250 lbs (113kg)

C/E/50HT400A/W – 310 lbs (141kg)  
C/E/50HR400A/W – 295 lbs (134kg)

Symphony, SensorSAFE, Maestro and SafeCLEAN are trademarks of Follett Corporation.  
Chewblet is a registered trademark of Follett Corporation, registered in the US.

Follett reserves the right to change specifications at any time without obligation. Certifications may vary depending on country of origin.

## Rear View

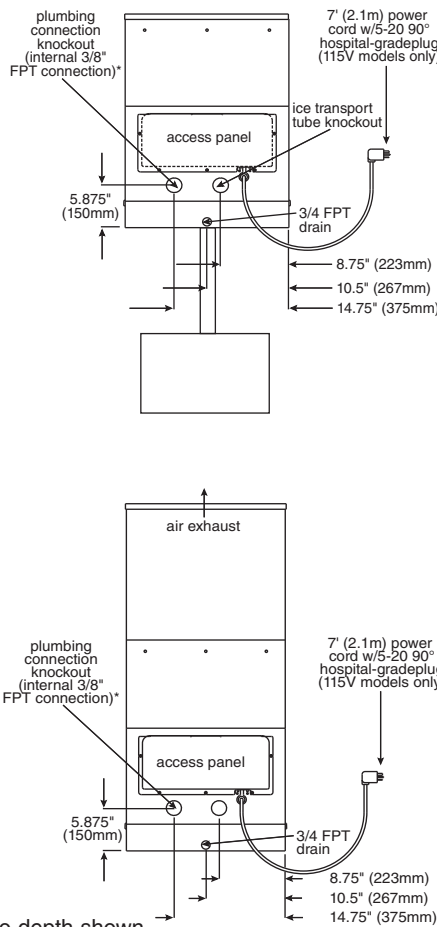

## Ice Production

Air-cooled icemaker capacity/24 hrs.

Inlet Water Temperature °F/C	Ambient Air Temperature F/C					
	F	60	70	80	90	100
50	510	454	397	335	273	lbs.
10	232	206	180	152	124	kg.
60	482	435	389	329	270	lbs.
16	219	198	177	150	123	kg.
70	454	417	380	323	266	lbs.
21	206	190	173	147	121	kg.
80	424	385	347	297	247	lbs.
27	193	175	158	135	112	kg.
90	394	354	313	270	227	lbs.
32	179	161	142	123	103	kg.

Water-cooled icemaker capacity/24 hrs.

Inlet Water Temperature °F/C	Ambient Air Temperature F/C					
	F	60	70	80	90	100
50	451	447	442	437	428	lbs.
10	204	202	200	199	194	kg.
60	423	413	409	399	394	lbs.
16	192	187	185	181	179	kg.
70	394	390	380	371	361	lbs.
21	179	177	172	168	163	kg.
80	371	361	352	342	333	lbs.
27	168	163	160	155	151	kg.
90	352	342	333	323	309	lbs.
32	160	155	151	146	140	kg.

## Heat Rejection Data

Model	Heat rejected in BTU/hr	
	to air	to water
Air-cooled	5000	n/a
Water-cooled	1400	3600

## Plug Configuration



\* Kit provided with all 230V, 50Hz and 220V, 60Hz models to connect to British Standard Pipe (BSP) water fittings.