

**To select dispense method:**

**Add -S after model number for SensorSAFE™ dispensing or -L for lever dispensing.**

**Countertop models with removable (A) air- or (W) water-cooled icemaker**

- 25CI400A – 115 V, 60 Hz, 25 lbs (11 kg) storage, air-cooled
- 25CI400W – 115 V, 60 Hz, 25 lbs (11 kg) storage, water-cooled
- 50CI400A – 115 V, 60 Hz, 50 lbs (22 kg) storage, air-cooled
- 50CI400W – 115 V, 60 Hz, 50 lbs (22 kg) storage, water-cooled

**Wall mount models with removable (A) air-cooled icemaker**

**Note:** Available with SensorSAFE dispensing only.  
 25HI400A-S – 115 V, 60 Hz, 25 lbs (11 kg) storage  
 50HI400A-S – 115 V, 60 Hz, 50 lbs (22 kg) storage

**Ice only models air-cooled only\***

**S after model number for SensorSAFE™ dispensing, L for lever dispensing and I denotes ice only**

- 25CI400A-SI – 115 V, 60 Hz, integral icemaker, SensorSafe, ice only
- 25CI400A-LI – 115 V, 60 Hz, integral icemaker, Lever, ice only
- 50CI400A-SI – 115 V, 60 Hz, integral icemaker, SensorSafe, ice only
- 50CI400A-LI – 115 V, 60 Hz, integral icemaker, Lever, ice only

\*Ice only models have a single chute.

Countertop and wall mount ice and water dispensers with removable air- or water-cooled icemaker located behind splash panel. Produces and automatically loads up to 400 lbs (181 kg) of Chewblet compressed nugget ice in a 24-hour period. Storage capacity of 25 lbs (11 kg) or 50 lbs (22 kg). Stainless steel exterior with plastic trim. Stainless steel frame. Water station standard.

**Add -S after model number for SensorSAFE dispensing or -L for lever dispensing.**

**Convenient, sanitary, user-friendly dispensing**

- Labor-saving, sanitary automatic load
- Available with lever or infrared SensorSAFE dispensing
- Quick shut-off reduces the amount of wasted ice
- 12" (305 mm) chute clearance accommodates large containers
- Lightweight, durable plastic lid lifts off easily for full access to storage hopper during cleaning and sanitizing

**SensorSAFE dispensing option offers improved sanitation and convenience**

- Infrared sensing reduces chance of cross contamination
- SensorSAFE not recommended for use with clear containers or for applications in direct sunlight

**Chewblet ice – perfect for healthcare and foodservice**

- Soft, chewable compressed nugget ice
- Consumer-preferred over cubes
- Slow melting, maintains drink temperature

**High performance Maestro icemakers**

- Removable modular icemaker slides out from behind front splash panel for convenient, easy access for service and cleaning at counter height
- R404A refrigerant with zero ozone depletion potential (ODP)

**Warranty**

- 3 years parts and labor
- 5 years compressor parts

**Accessories**

- Water filter kit (item# 00130229)
- High capacity water filter kit (item# 00978957)
- 4" (102 mm) leg kit (item# 00188417)
- Base stand (item# AF50BASESTD)
- SafeCLEAN™ environmentally responsible icemaker cleaner (item# 00132001)
- Drain pan kit for wall mount models (item# 00188839 – 25HI400A; item# 00188821 – 50HI400A)



25CI400A-S (countertop with SensorSAFE™ "-S" ice and water dispensing)

*Symphony™*

*Follett's exclusive modular icemaking unit slides out from behind front panel*

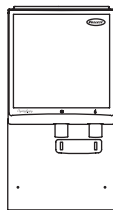

Wall mount model\*\* (SensorSAFE dispensing only)

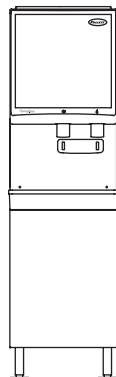

Countertop model with base stand\*

JOB: \_\_\_\_\_

ITEM: \_\_\_\_\_

\* See form# 2145 for specifications on base stand accessory.  
 \*\* No drain pan. Drain pan available – contact factory.

# 25 Series 50 Series

# Symphony™ countertop and wall mount ice and water dispensers with Maestro™ Chewblet® ice icemaker

**Front View** **Right Side View** **Rear View**

**Countertop models**  
(shown with lever dispensing (-L); infrared SensorSAFE dispensing (-S) available)

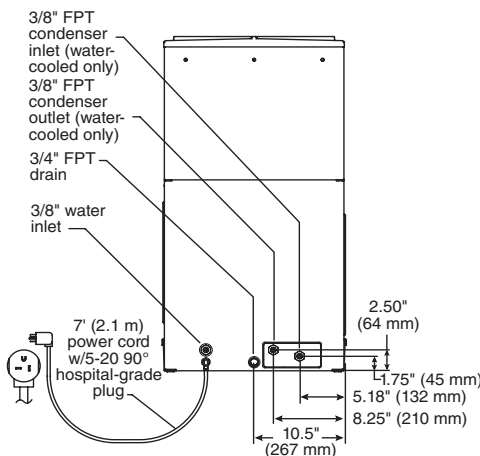
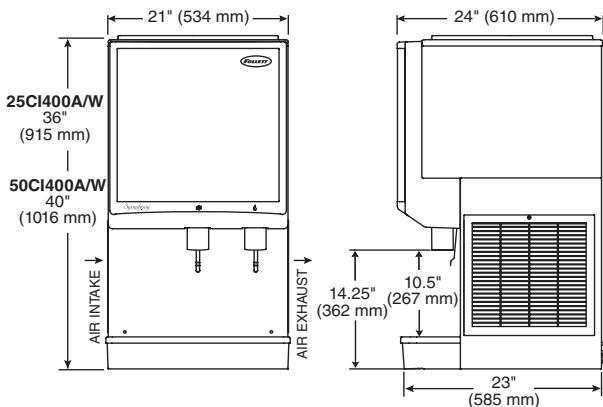

**Wall mount models**  
(available only with infrared SensorSAFE dispensing (-S))

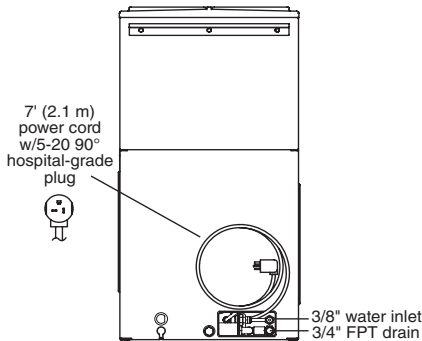
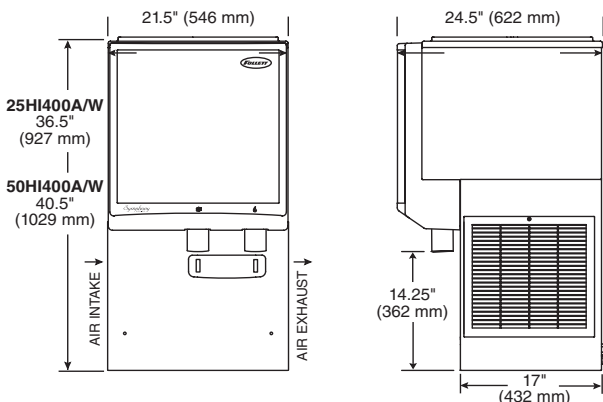

### Clearances

	Air-cooled	Water-cooled
<b>Required for ventilation</b>	3" (77 mm) each side	N/A
<b>Recommended for service</b>	12" (305 mm) top; 6" (153 mm) left side	12" (305 mm) top

### Operating limits

Ambient air temp. range – 50 F to 100 F (10 C to 30 C).  
Water temp. range – 40 F to 90 F (5 C to 32 C).  
Potable water pressure – 10 psi to 70 psi (69 kpa to 483 kpa).  
Condenser water pressure – 10 psi to 150 psi (69 kpa to 1035 kpa) maximum.

### Electrical

115 V, 60 Hz, 1 phase, 14.0 amps. Connect to dedicated 20 amp circuit.  
**Note:** It is preferred that circuit be protected by a GFCI breaker.  
Furnished with 7 ft (2.1 m) power cord with a 90° NEMA hospital-grade 5-20 plug.

**Approximate shipping weight** 255 lbs (116 kg)

### Specifications

Ice and water dispenser to be Follett automatic load in (choose one) \_\_\_ countertop or \_\_\_ wall mount configuration, with \_\_\_ 25 lbs (11 kg) or \_\_\_ 50 lbs (22 kg) of storage. Environmentally responsible R404A icemaker to be (choose one) \_\_\_ air- or \_\_\_ water-cooled and to be removable for cleaning and maintenance. Dispenser frame and cabinet to be stainless steel with plastic trim. Icemaker to produce approximately 400 lbs (181 kg) of Chewblet compressed nugget ice at air temp. of 70 F (21 C), water temp. of 50 F (10 C). Icemaker to be equipped with printed circuit board and diagnostics to allow simplified servicing. Dispenser to have automatic bin level control to start and stop icemaker and lightweight plastic top that allows full access to the ice storage area for easy cleaning and manual loading of back-up ice. Storage area to be insulated with non-CFC, high density, foamed-in-place polyurethane. 7 ft (2.1 m) cord and NEMA 5-20 hospital-grade plug provided. Dispenser to be NSF and ETL listed.

Maestro, SafeCLEAN, SensorSAFE and Symphony are trademarks of Follett Corporation.  
Chewblet and Follett are registered trademarks of Follett Corporation, registered in the US.  
Follett reserves the right to change specifications at any time without obligation. Certifications may vary depending on country of origin.

### Countertop models

- Utilities connect through back or bottom. Back entry shown.
- See Dispenser Detail Sheet, form# 2075, for counter cut outs

### Wall mount models

- Utilities connect through back only
- Wall mount bracket standard
- SensorSAFE dispensing only
- Standard without drain pan. Drain pan available – contact factory.
- See Dispenser Detail Sheet, form# 2075, for minimum sink dimensions

### Ice production

Inlet Water Temperature °F/C	Ambient Air Temperature °F/C				
	F 60	70	80	90	100
50	425	395	360	330	295
10	193	180	164	150	134
60	410	380	345	315	285
16	186	173	157	143	130
70	395	365	330	300	270
21	180	166	150	137	123
80	380	350	318	285	255
27	173	159	145	130	116
90	365	335	305	273	243
32	166	152	139	124	111

### Water-cooled icemaker capacity/24 hrs.

Inlet Water Temperature °F/C	Condenser Water Inlet Temperature °F/C				
	F 60	70	80	90	100
50	430	425	418	390	350
10	195	193	190	177	159
60	415	406	392	368	334
16	188	184	178	167	152
70	401	386	365	345	318
21	182	175	166	156	144
80	385	365	340	323	304
27	175	166	154	147	138
90	368	343	315	300	290
32	167	156	143	136	132

### Water flow requirements for water-cooled condensers

Water Temp. °F/°C	50/10	60/16	70/21
Water Flow:			
Gallons/100 lbs of ice	60	120	185
Liters/46 kg of ice	227	454	700

### Energy consumption

KWH per 100 lbs (46 kg) ice†	
Air-cooled	5.7
Water-cooled	5.5

† Air temp. 90 F (32 C); water temp. 70 F (21 C)

### Heat rejection data

Model	Heat rejected in BTU/hr	
	to air	to water
Air-cooled	5000	N/A
Water-cooled	1400	3600

### Water consumption

12.6 gal (48 L) of potable water usage per 100 lbs (46 kg) of ice.