

CAMBRO®

Ultra Pan Carrier® S-Series Stack-and-Store

Top Loading

For GN Full Size Food Pans

Model UPCSS160

Features & Benefits



- This streamlined carrier features insulated lids and bases that nest together for compact storage and weighs 20% less than the Cambro UPCS160. This carrier is an economical and durable choice that is ideal for large-scale operations where storage and transport are required.
- Perfect for transporting hot or cold food to off premise events, corporate parties or delivering food from central kitchens to satellite locations.
- Use with Cambro Food Pans and GripLids®.
- Holds either a Cambro GN full size 6" (15 cm) deep food pan or a GN full size 4" (10 cm) deep food pan with a Camchiller®. Does not hold divider bars or fractional pans.
- No removable gasket: built-in seal offers excellent temperature retention, easier cleaning and reduced replacement costs.
- For best holding results, pre-heat or pre-chill unit prior to use for 20-30 minutes. Use hot water or ice and keep lid closed. Use a Camchiller with a GN full size 4" (10 cm) deep food pan with GripLid to maintain cold temperatures for a longer duration. Do not use any flame or electrical sources.
- Durable polypropylene construction is lightweight and dishwasher safe. Foamed-in polyurethane insulation helps to ensure hot and cold foods are held at safe temperatures.
- Self-venting design helps equalize pressure and release steam.
- Four wide, nylon latches are easy to open and close, are rust-proof and close tightly to seal in contents.
- Easy to load and unload heavy food pans using molded-in finger notches.
- Molded-in handles on all four sides provide comfortable, easy transporting.
- Cantilevered base reduces stacking and storage height by up to 35%.
- Smooth areas on lid and carrier make labeling easy.
- No assembly required.
- Available in 2 colors.

Item No. _____

Specifier Identification No. _____

Model No. _____

Quantity _____



UPCSS160



Hot

UPCSS160	190°F	178°F	174°F	170°F	166°F
	87,8°C	81,1°C	78,9°C	76,7°C	74,4°C
Starting Temperature	1 hr.	2 hrs.	3 hrs.	4 hrs.	

Cold

UPCSS160	32°F	33°F	35.4°F	37°F	38.8°F
	0°C	0,5°C	1,9°C	2,8°C	3,8°C
Starting Temperature	1 hr.	2 hrs.	3 hrs.	4 hrs.	

Approvals



CAMBRO®
www.cambro.com

DURABILITY THAT MAKES A DIFFERENCE®

CAMBRO

Ultra Pan Carrier® S-Series Stack-and-Store

Item No. _____

Specifier Identification No. _____

Model No. _____

Quantity _____

Top Loading

For GN Full Size Food Pans

Model UPCSS160

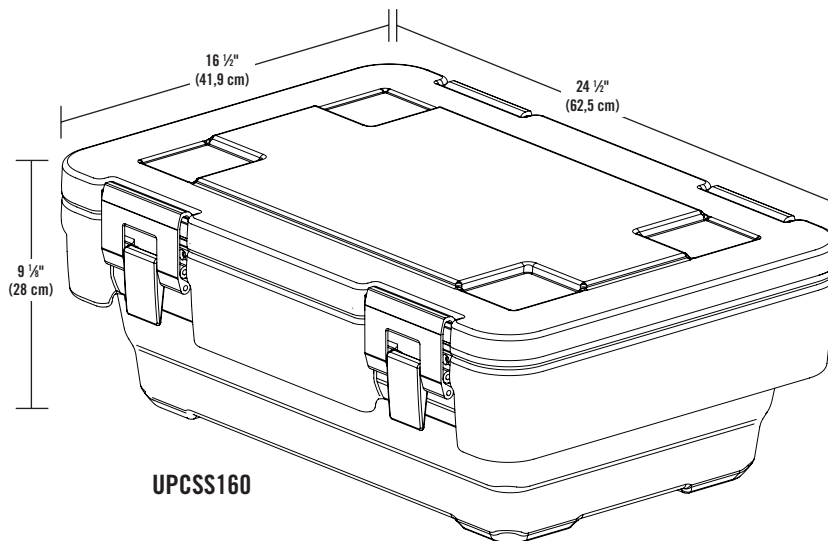

Specifications

Code	Description	Food Pan Depth	Approx. Capacity	Exterior Dimensions L x W x H	Interior Dimensions	Case Weight/Cube
UPCSS160	Ultra Pan Carrier S-Series Stack-and-Store	6" (15 cm) 4" (10 cm)	20 qts. (18,9 L)	24 1/2" x 16 1/2" x 9 1/8" 62,2 x 41,9 x 23,18 cm	Top: 21 3/8" x 13 1/2" (54,29 x 34,29 cm) Depth: 6 3/4" (17 cm) Bottom: 19" x 11" (48,26 x 28 cm)	16.81 lbs. (2.435 ft³) 7,64 Kg. (0,07 m³)

UPCSS160 Standard Colors

- Coffee Beige (157)
- Dark Brown (131)

Optional Accessories

- Camdolly**
 - CD160
- Colors**
 - Coffee Beige (157)
 - Dark Brown (131)
 - Black (110)
 - Slate Blue (401)
 - Gray (180)

Architect Specs

The portable non-electrical hot and cold GN food pan transport carrier shall be an Ultra Pan Carrier® S-Series Stack-and-Store, Model UPCSS160, manufactured by Cambro Mfg. Co., Huntington Beach, CA 92647 USA. It shall be made of polypropylene and shall be injected with polyurethane foam. It shall have a self-venting feature to help equalize pressure and release steam. It shall have a built-in gasket that is non-removable. It shall transport GN Full Size Food Pans. It shall have four durable, nylon latches on the sides and smooth areas on the lid and side for labeling. It shall have E-Z grip molded-in handles on all four sides. It shall have a cantilevered base and interlocking design to provide compact stacking for storage and transport. It shall require no assembly and shall be available in two colors.

Approvals



CAMBRO
www.cambro.com

DURABILITY THAT MAKES A DIFFERENCE®

© 2009 Cambro Manufacturing Company 5801 Skylab Road, Huntington Beach, CA 92647-2056, USA
Telephone 714 848 1555 Toll Free 800 854 7631 Customer Service 800 833 3003

CS 091555JPN 6060101