

Portable Cambar[®] Designer Series

650 Designer Series

Post-Mix

Domestic Models

BAR650DSPMT - Post-Mix

BAR650DSPM - Post-Mix for Municipal Water Supply

International Model

BAR650DSPMT2 - 220 Volt

Features & Benefits

- Engineered to fit in standard elevators to be easily moved between locations. Ideal for suites and smaller gatherings.
- Decorative counter and front and side panels for upgraded appearance to fit in any decor. Panels are made from a thermoformed ABS plastic with a clear finish for UV, scratch and chemical resistance. Counter is a granite pattern over a fiberglass composite structure.
- Unique detachable front lifts off, giving complete access to all storage areas for inventory and cleaning or routing soda lines, tubes and hoses.
- Sealed-in eight-circuit patented cold plate has unique "roof top" design that directs melted water immediately into drainage channels and into the waste water bin. Keeps ice colder longer.
- Premium quality Wunder-Bar[®] 5-button post-mix soda gun offers fast, low foaming delivery.
- Oversized 7-bottle speed rail with towel grips is standard with all models. Detaches for easy cleaning. Built in partitions keep bottles separated to prevent breakage.
- BAR650DSPMT/BAR650DSPMT2 includes:
 - One 5-button Wunder-Bar[®] gun, sealed-in cold plate,
 - 1 carbonator, 3 syrup pumps, 1 CO₂ regulator and gauge,
 - 1 CO₂ clamp and chain, 1 steel bag-in-box rack, tubing, hose and lines, 1 speed rail, 1 retainer strap, 1 waste water bin, 1 each 80 lb. (37 Kg.) ice sink and cover, 1 each 17 gallon (64 L) fresh water tank, 1 water pump.
- BAR650DSPM includes:
 - One 5-button Wunder-Bar gun, sealed in cold plate,
 - 1 carbonator, 3 syrup pumps, 1 CO₂ regulator and gauge,
 - 1 CO₂ clamp and chain, 1 steel bag-in-box rack, tubing, hose and lines, 1 speed rail, 1 retainer strap, 1 waste water bin, 1 each 80 lb. (37 Kg.) ice sink and cover.
- Molded high-density polyethylene is impact resistant and easy to clean. Won't dent, crack, rust, chip or break.
- Reinforced aluminum chassis and polyurethane structural foam core ensures unsurpassed strength.
- Ice sink, 80 lb. (37 Kg.) capacity with slide back cover for optimum sanitation.
- Four each 6" (15.2 cm) swivel casters, 2 w/ brakes for smooth transport across carpet, cement or grass.
- Electrical 110 volt or 220 volt.
- Minimal assembly required.
- Available in 3 decor combinations.

Item No. _____

Specifier Identification No. _____

Model No. _____

Quantity _____



BAR650DSPMT



Manhattan Decor Combination (667)



Carmel Decor Combination (669)



Premium quality 5-button, post-mix soda gun by Wunder-Bar[®] with fast, low foaming delivery.



Detachable front for easy access to inventory and routing lines, tubes and hoses.

Approvals



Carbonator and Water Pumps only

Portable Cambar® Designer Series

650 Designer Series

Post-Mix

Domestic Models

BAR650DSPMT - Post-Mix

BAR650DSPM - Post-Mix for Municipal Water Supply

International Model

BAR650DSPMT2 - 220 Volt

Item No. _____

Specifier Identification No. _____

Model No. _____

Quantity _____

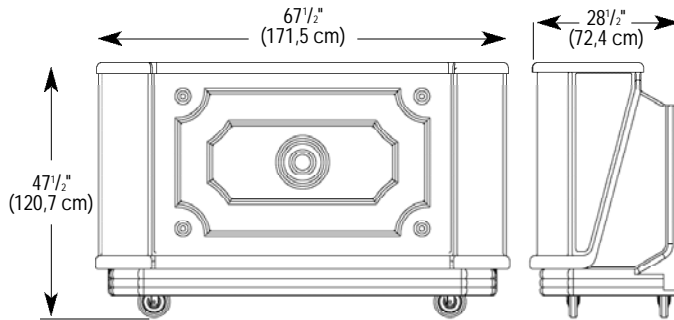

Sedona and Carmel Decor Packages
Front Panel Design

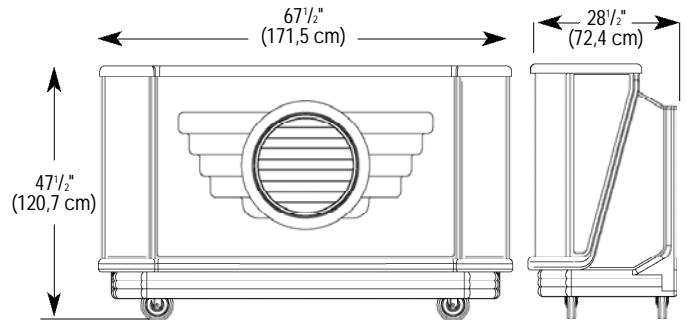

Manhattan Decor Package
Front Panel Design

BAR650DSPMT / BAR650DSPM / BAR650DSPMT2

Specifications

Dimension Tolerance: +/- 1/4" (0,64 cm)

Code	Description	Overall Dimensions L x W x H	Case lbs./cube Kg/m ³
BAR650DSPMT	Cambar with one 5-button Wunder-Bar® gun, sealed-in cold plate, 1 carbonator, 6 syrup pumps, 1 CO ₂ regulator and gauge, 1 CO ₂ clamp and chain, 1 steel bag-in-box rack, tubing, hose and lines, 1 speed rail, 1 retainer strap, 1 waste water bin, 1 each 80 lb. (37 Kg.) center ice sink and cover, 1 each 17 gallon (64 L) fresh water tank, 1 water pump and decorative counter and front and side panels.	67 1/2" x 28 1/2" x 47 1/2" (171,5 x 72,4 x 120,7 cm)	387 (59.09) 175,5 (1,67)
BAR650DSPM	Cambar with one 5-button Wunder-Bar® gun, sealed-in cold plate, 1 carbonator, 3 syrup pumps, 1 CO ₂ regulator and gauge, 1 CO ₂ clamp and chain, 1 steel bag-in-box rack, tubing, hose and lines, 1 speed rail, 1 retainer strap, 1 waste water bin, 1 each 80 lb. (37 Kg.) center ice sink and cover and decorative counter and front and side panels.	67 1/2" x 28 1/2" x 47 1/2" (171,5 x 72,4 x 120,7 cm)	367 (59.09) 166,5 (1,67)
BAR650DSPMT2	Cambar with same accessories as BAR650DSPMT. Available in 220 volt. No plug will be furnished.	67 1/2" x 28 1/2" x 47 1/2" (171,5 x 72,4 x 120,7 cm)	387 (59.09) 175,5 (1,67)

Optional Accessories

- Wire Shelving 730WS
- Retaining Strap 730STP (2 each with Cambar)
- Retaining Chain for CO₂ canisters 730CHN (1 each with Cambar)
- 7-Bottle Speed Rail 730SR (1 each with Cambar)
- 17 gal. (64 L) Fresh Water Tank 730FWT (1 each with Cambar BAR650DSPMT)

Standard Colors

- Manhattan - Black base, Coal countertop and Brushed Pewter panels (667)
- Sedona - Granite Sand base, Cocoa countertop and Light Burlwood panels (668)
- Carmel - Black base, Coal countertop and Dark Burlwood panels (669)

Architect Specs

The post-mix designer series portable bar shall be a Cambar650 Designer Series, manufactured by Cambro Mfg. Co., Huntington Beach, CA 92648 U.S.A. It shall be a Cambro Model... It shall be constructed of molded high-density polyethylene and foam-injected polyurethane with a built-in bumper and decorative counter and front and side panels. It shall have an access passage for a water line or electrical cord. It shall have a step-down preparation area that can be fit with 2 glass rail mats. It shall have 4 each 6" (15,2 cm) swivel casters, 2 locking, on a molded-in aluminum chassis. It shall have a premium 5-button Wunder-Bar® post-mix soda gun, sealed-in 8-circuit "roof top" design

cold plate, CO₂ regulator and gauge, CO₂ clamp and chain, 7-bottle oversized speed rail with built-in partitions and towel grips, and waste water bin. It shall have 3 each mechanical syrup pumps, 1 each steel bag-in-the-box rack, and the required tubing, hoses and lines. It shall have a UL Approved carbonator. It shall be offered in both 110V and 220V models. It shall have an 80 lb. (37 Kg.) capacity center ice bin with a slide back cover. It shall be available with a 17-gallon (64 L) fresh water tank and one UL Approved electrical water pump. It shall have a detachable front that lifts off. All models shall be available in three decor combinations.

Approvals



Carbonator and Water Pumps only