



# BEVERAGE-AIR

3779 Champion Blvd., Winston-Salem, NC 27105  
1-888-845-9800 Fax# 1-336-245-6453  
<http://www.Beverage-Air.com>

Item No. \_\_\_\_\_  
Quantity \_\_\_\_\_

## COUNTERTOP MERCHANDISER SERIES CF3 Countertop Freezer

MODELS:  
CF3

### Commercial Refrigeration Equipment General Specification

#### CF3 SERIES—COUNTERTOP FREEZER

Used for merchandising and storage of frozen product. Ideal for ice cream shops, restaurants, bars, supermarkets and convenience stores. Requires minimum countertop space.

#### CABINET CONSTRUCTION

Heavy duty construction includes pre-painted steel interior and exterior for easy cleaning.

Right-hand hinged door standard with insulated glass and stylish handle.

3 adjustable shelves included.

#### REFRIGERATION

Cold wall refrigeration system uses R404A refrigerant, which is CFC-free for compliance with environmental safety concerns. Operating temperature of -1°F (-18°C).

Ambient conditions of 72°F at 65% relative humidity.

#### ELECTRICAL

Side, interior fluorescent lighting enhances product illumination.

Units wired at factory and ready for connection to a 115/60/1 phase, 15 amp dedicated outlet. 6.5' long cord and plug set included.

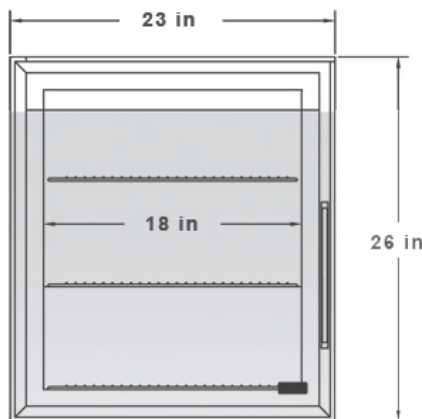

#### ELECTRICAL CONNECTION

Units pre-wired at factory and include 6.5' long cord and plug set.



CF3

MODEL	CF3
<b>EXTERNAL DIMENSIONAL DATA</b>	
Length Overall (inches)	23"
Length Overall (mm)	584
Depth Overall (inches)	24"
Depth Overall (mm)	610
Height Overall— (inches)	26"
Height Overall— (mm)	660
Number of doors	1
<b>INTERNAL DIMENSIONAL DATA</b>	
NET Capacity (cubic ft.)	3
NET Capacity (Liters)	85
Number of shelves	3
<b>ELECTRICAL DATA</b>	
Full Load Amperes 115/60/1	3
<b>REFRIGERATION DATA</b>	
Horsepower	1/6
<b>WEIGHT DATA</b>	
Gross Weight (Crated lbs)	110
Gross Weight (Crated kg)	50



\*Note: Not all markings may apply to all model variations.

Available From:

## BEVERAGE-AIR® CORPORATION

3779 Champion Blvd. • Winston-Salem, NC 27105 USA • (336) 245-6400 • Fax (336) 245-6453 • (888) 845-9800 • [www.beverage-air.com](http://www.beverage-air.com)

Specifications are subject to change without prior notice. 10/11

