

# TUC Series

## Undercounter Refrigerators / Freezers



Both durable and compact, the TUC Series of undercounter refrigerators and freezers keep refrigerated or frozen ingredients right where you need them in prep or server's areas. An enhanced cold air circulation system, coupled with a high quality stainless steel interior and exterior makes the TUC Series the best undercounter refrigerators and freezers on the market.



- High quality stainless steel interior & exterior
- Foamed-in-place high density polyurethane cell insulation
- Self closing doors
- ETL Safety & Sanitation Approved



With its compact size and all stainless steel interior and exterior, this single door undercounter freezer is a perfect addition to snack bars, concession stands, pizzerias, sandwich shops, and restaurant kitchens with limited space. Built in casters, two of which are locking, allow you to pull the freezer out from under your countertops, for easy cleaning and service.

A plastic coated steel shelf is included. Adjustable mounting brackets give you complete control over the freezer's shelving configuration, to accommodate a variety of toppings, garnishes, or condiments. The door comes hinged on the right, but is field reversible.

The 27" undercounter freezer's 1/4 hp compressor uses R404a refrigerant. Foamed in place polyurethane cell insulation helps maintain interior temperatures between -7° and 0° Fahrenheit. A top mounted cooling fan circulates air quickly throughout the freezer, regulating the internal temperature even when the freezer's self-closing door is opened.

With its durable, 430 series stainless steel exterior and 304 series stainless steel interior, the single door undercounter freezer is strong enough to stand up to the daily demands of your busy restaurant kitchen. The single door undercounter freezer has a 120V, 5.2 amp, 60 Hz. electrical rating, and is ETL Sanitation Listed and NSF Compliant.

## Features

- 304 series stainless steel interior
- 430 series stainless steel exterior
- Recessed handle
- 1 plastic coated steel shelf included
- Foamed in place polyurethane insulation
- Removable door gasket for easy cleaning
- Self closing door
- Automatic defrosting
- 4 casters (two locking)
- ETL Sanitation Listed

## Technical Data

### Dimensions

Exterior Dimensions (W x D x H)	27.5" x 30" x 35"
Interior Dimensions (W x D x H)	22.25" x 22.75" x 23.5"
Net Volume (cu. ft.)	6.25 cu. ft.
Net Weight	158.5 lbs.
Packaging Dimensions (W x D x H)	29" x 31.75" x 36.25"

### Cooling

Temperature Range	-7° - 0° F
Refrigerant	R404a
Maximum Ambient Temperature Rating	100.4° F
Defrosting	Automatic
Temperature Display	No
Temperature Controller	Mechanical
Horsepower	1/4

### Construction

Exterior Material	430 Series Stainless Steel
Interior Material	304 Series Stainless Steel
Insulation Material	Foamed in Place Polyurethane
Shelf Material	Plastic Coated Steel
Shelf Load Capacity	90 lbs.

### Electrical

Voltage	120
Amps	5.2
Hz	60
Phase	1
Electrical Cord Length	84"

## Plan View

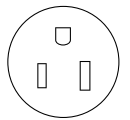
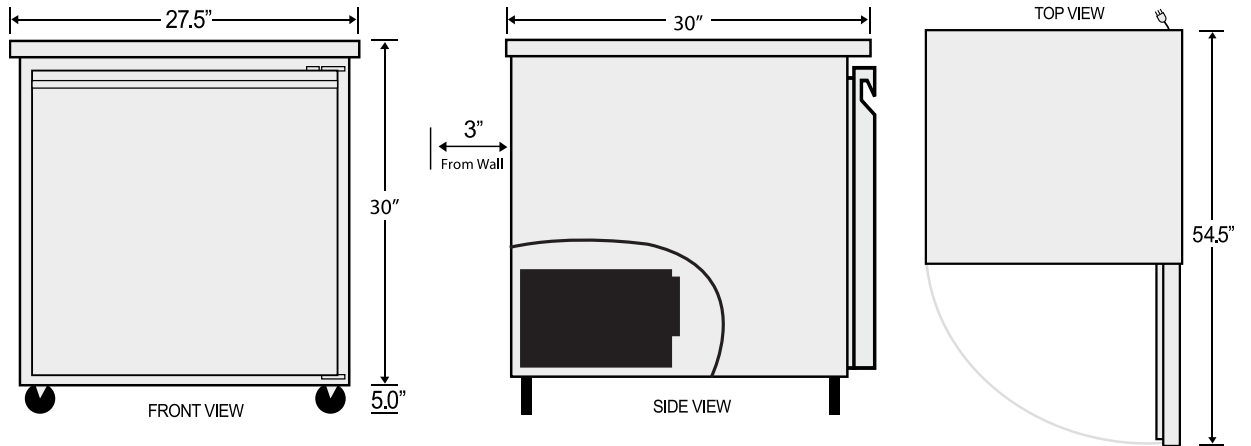

NEMA 5-15P



**1 year**  
WARRANTY

Parts & Labor



**5 year**  
WARRANTY

Compressor

All Avantco Refrigerators and Freezers are backed by a 1 year parts and labor warranty, with a 5 year warranty on the compressor. For warranty inquiries or service, first locate the serial number plate on the front of the unit, or inside the door jamb. Next, call 1-800-678-5517. Be sure to have the serial and model numbers available when contacting service technicians.