

SCL Series

Sandwich / Salad Prep Refrigerators



The SCL Series sandwich / salad prep refrigerators provides both an ample work area and exceptional storage space. With a durable, stainless steel interior and exterior, built-in casters, and self closing doors, the SCL Series is designed for unmatched efficiency at an unbeatable price.



- High quality stainless steel interior & exterior
- Foamed-in-place high density polyurethane cell insulation
- Insulated lid
- ETL Safety & Sanitation Approved
- 3/4" thick cutting board





With its durable, 430 series stainless steel exterior and 304 series stainless steel interior, the Avantco SCLM2 48" mega sandwich / salad prep refrigerator is strong enough to stand up to the daily demands of your busy restaurant kitchen.

This over-sized, 48" mega sandwich / salad refrigerator features a stainless steel, slide rail work area and a cold topping holding area that can hold up to eighteen, 1/6 size food pans up to 6" deep. The topping rail will also hold 1/4, 1/3, 1/2, and full size food pans.

An insulated, hinged cover helps keep your condiments, meats, and vegetables cold during off-peak hours. Built in casters, two of which are locking, allow you to move the sandwich / salad refrigerator for easy cleaning and servicing.

Store additional toppings for quick access in the sandwich / salad preparation refrigerator's lower section. The lower refrigerator has two self closing doors and two plastic coated wire shelves. Adjustable mounting brackets give you complete control over the refrigerator's shelving configuration, to accommodate a variety of prepared toppings, garnishes, dressings, and condiments.

The Avantco SCLM2 refrigerator's 1/3 hp compressor uses R134a refrigerant. Foamed in place CFC-free insulation helps maintain interior temperatures between 32 and 50 degrees Fahrenheit. An interior fan regulates the refrigerator's temperature and directs cool air upward, to help keep your toppings at food safe holding temperatures.

The Avantco SCLM2 mega sandwich / salad prep refrigerator has a 120V, 8.1 amp, 60 Hz. electrical rating, and is ETL Sanitation Listed and NSF Compliant.

Features

- 304 series stainless steel interior
- 430 series stainless steel exterior
- 3/4" thick cutting board
- Recessed door handles
- 2 plastic coated steel shelves included
- Foamed in place polyurethane insulation
- Insulated lid
- Removable door gasket for easy cleaning
- Self closing doors
- Automatic defrosting

Technical Data

Dimensions

Exterior Dimensions (W x D x H)	47" x 35.5" x 46"
Interior Dimensions (W x D x H)	42.75" x 23.75" x 23.5"
Cutting Board Dimensions (W x D x H)	46.5" x 7" x .75"
Net Volume (cu. ft.)	9.75 cu. ft.
Net Weight	253 lbs.
Packaging Dimensions (W x D x H)	51" x 34" x 45.5"

Cooling

Temperature Range	32° - 50° F
Refrigerant	R134a
Maximum Ambient Temperature Rating	90° F
Defrosting	Automatic
Temperature Display	Yes
Temperature Controller	Mechanical
Horsepower	1/3

Construction

Exterior Material	430 Series Stainless Steel
Interior Material	304 Series Stainless Steel
Insulation Material	Foamed in Place Polyurethane
Shelf Material	Plastic Coated Steel
Shelf Load Capacity	90 lbs.

Electrical

Voltage	120
Amps	8.1
Hz	60
Phase	1
Electrical Cord Length	84"

Plan View

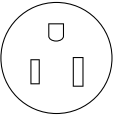
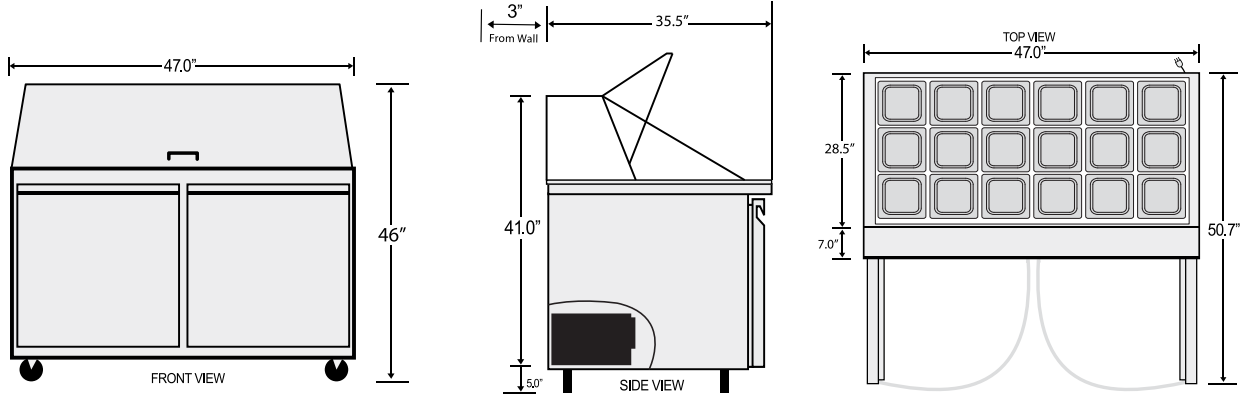

NEMA 5-15P



1 year
WARRANTY

Parts & Labor



5 year
WARRANTY

Compressor

All Avantco Refrigerators and Freezers are backed by a 1 year parts and labor warranty, with a 5 year warranty on the compressor. For warranty inquiries or service, first locate the serial number plate on the front of the unit, or inside the door jamb. Next, call 1-800-678-5517. Be sure to have the serial and model numbers available when contacting service technicians.