

# SCL Series

## Sandwich / Salad Prep Refrigerators



The SCL Series sandwich / salad prep refrigerators provides both an ample work area and exceptional storage space. With a durable, stainless steel interior and exterior, built-in casters, and self closing doors, the SCL Series is designed for unmatched efficiency at an unbeatable price.



- High quality stainless steel interior & exterior
- Foamed-in-place high density polyurethane cell insulation
- Insulated lid
- ETL Safety & Sanitation Approved
- 3/4" thick cutting board





### Features

- 304 series stainless steel interior
- 430 series stainless steel exterior
- Recessed door handles
- 3 plastic coated steel shelves included
- Self closing doors
- Foamed in place polyurethane insulation
- Insulated lid
- Removable door gaskets for easy cleaning
- Automatic defrosting
- 4 casters (two locking)
- ETL Sanitation Listed

### Technical Data

#### Dimensions

Exterior Dimensions (W x D x H)	71" x 31" x 42.5"
Interior Dimensions - Top (W x D x H)	66" x 8.5" x 13.25"
Interior Dimensions - Bottom (W x D x H)	66" x 19" x 20"
Cutting Board Dimensions (W x D x H)	70" x 10.5" x .75"
Net Volume (cu. ft.)	18 cu. ft.
Net Weight	513 lbs.
Packaging Dimensions (W x D x H)	75.75" x 35" x 46"

#### Cooling

Temperature Range	32° - 50°
Refrigerant	R134a
Maximum Ambient Temperature Rating	90°
Defrosting	Automatic
Temperature Display	Yes
Temperature Controller	Mechanical
Horsepower	1/2

#### Construction

Housing Material	430 Series Stainless Steel
Door/Lid Material	304 Series Stainless Steel
Insulation Material	Foamed in Place Polyurethane
Shelf Material	Plastic Coated Steel
Shelf Load Capacity	90 lbs.

#### Electrical

Voltage	120V
Amps	7.6
Hz	60
Phase	1
Electrical Cord Length	84"

With its durable, 430 series stainless steel exterior and 304 series stainless steel interior, the Avantco SCL3 71" sandwich / salad prep refrigerator is strong enough to stand up to the daily demands of your busy restaurant kitchen.

This Avantco SCL3 71" sandwich / salad refrigerator features a stainless steel, slide rail work area and a cold topping holding area that can hold up to eighteen, 1/6 size food pans up to 6" deep. The topping rail will also hold 1/9, 1/3, and full size food pans.

An insulated, hinged cover helps keep your condiments, meats, and vegetables cold during off-peak hours. Built in casters, two of which are locking, allow you to move the sandwich / salad refrigerator for easy cleaning and servicing.

Store additional toppings for quick access in the sandwich / salad preparation refrigerator's lower section. The lower refrigerator has three self closing doors and three plastic coated wire shelves. Adjustable mounting brackets give you complete control over the refrigerator's shelving configuration, to accommodate a variety of prepared garnishes, dressings, and condiments.

The Avantco SCL3 refrigerator's 1/2 hp compressor uses R134a refrigerant. Foamed in place CFC-free insulation helps maintain interior temperatures between 32 and 50 degrees Fahrenheit. An interior fan regulates the refrigerator's temperature and directs cool air upward, to help keep your toppings at food safe holding temperatures.

The Avantco SCL3 sandwich / salad prep refrigerator has a 120V, 7.6 amp, 60 Hz. electrical rating, and is ETL Sanitation Listed and NSF Compliant.

# Plan View

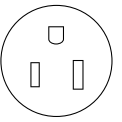
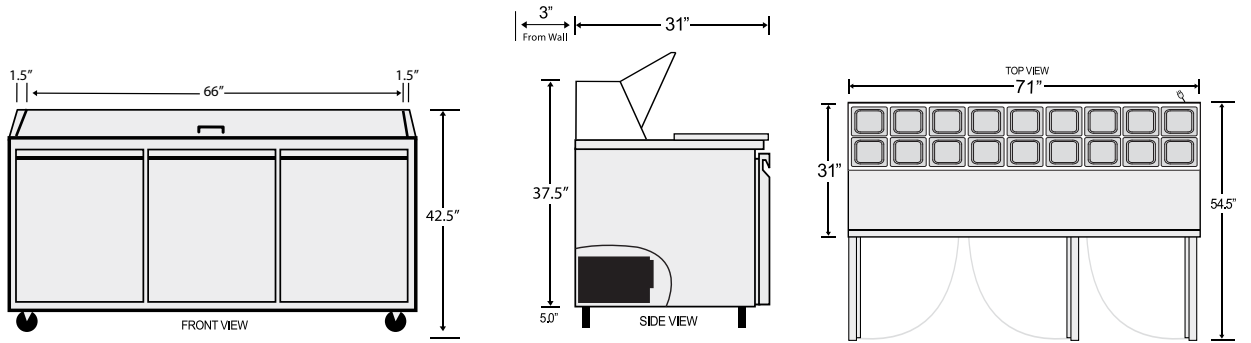

NEMA 5-15P



**1 year**  
WARRANTY

Parts & Labor



**5 year**  
WARRANTY

Compressor

All Avantco Refrigerators and Freezers are backed by a 1 year parts and labor warranty, with a 5 year warranty on the compressor. For warranty inquiries or service, first locate the serial number plate on the front of the unit, or inside the door jamb. Next, call 1-800-678-5517. Be sure to have the serial and model numbers available when contacting service technicians.