

PICL Series

Refrigerated Pizza Prep Tables

With a durable, stainless steel interior and exterior, the PICL Series of refrigerated pizza prep tables are built to handle the daily demands of your busy kitchen. Thanks to an ample amount of storage space and superior air circulation, the PICL Series offers exceptional performance at an unbeatable price.

- Foamed-in-place high density polyurethane cell insulation
- ETL Safety & Sanitation Approved
- Full length, 19" deep cutting board
- Insulated Lid



PICL Series 178PICL3

Features

- 304 series stainless steel interior
- 430 series stainless steel exterior
- 19" deep cutting board
- Recessed door handles
- 3 plastic coated steel shelves included
- Foamed in place polyurethane insulation
- Insulated lid
- Removable door gasket for easy cleaning
- Self closing doors
- Automatic defrosting
- 4 casters (two locking)
- ETL Sanitation Listed



With its durable, 430 series stainless steel exterior and 304 series stainless steel interior, the Avantco PICL3 93" refrigerated pizza prep table is strong enough to stand up to the daily demands of your busy restaurant kitchen.

This Avantco PICL3 93" refrigerated pizza prep table features an extra-wide work area, and a cold topping holding area that can hold up to twelve, 1/3 size food pans up to 6" deep.

An insulated, hinged cover lets you keep your sauces and toppings cold during off-peak hours. Built in casters, two of which are locking, allow you to move the pizza refrigerator for easy cleaning and service.

The 93" pizza prep table also features a refrigerator with three self closing doors, for storing additional toppings. Three plastic coated steel shelves are included. Adjustable mounting brackets give you complete control over the refrigerator's shelving configuration, to accommodate a variety of prepared toppings, garnishes, or condiments.

The Avantco PICL3 93" refrigerated pizza prep table's 1/2 hp compressor uses R134a refrigerant. Foamed in place CFC-free insulation helps maintain interior temperatures between 32 and 50 degrees Fahrenheit. An interior fan regulates the refrigerator's temperature and directs cool air upward, to help keep your toppings at food safe holding temperatures.

The Avantco PICL3 pizza prep table has a 120V, 11.1 amp, 60 Hz. electrical rating, and is ETL Sanitation Listed and NSF Compliant.

Technical Data

Dimensions

| | |
|--------------------------------------|------------------------|
| Exterior Dimensions (W x D x H) | 92" x 31.5" x 44" |
| Interior Dimensions (W x D x H) | 69.5" x 22.75" x 23.5" |
| Cutting Board Dimensions (W x D x H) | 91.75" x 19" x .75" |
| Net Volume (cu. ft.) | 24 cu. ft. |
| Net Weight | 440 lbs. |
| Packaging Dimensions (W x D x H) | 96.25" x 36" x 46" |

Cooling

| | |
|------------------------------------|-------------|
| Temperature Range | 32° - 50° F |
| Refrigerant | R134a |
| Maximum Ambient Temperature Rating | 90° F |
| Defrosting | Automatic |
| Temperature Display | No |
| Temperature Controller | Mechanical |
| Horsepower | 1/2 |

Construction

| | |
|---------------------|------------------------------|
| Exterior Material | 430 Series Stainless Steel |
| Interior Material | 304 Series Stainless Steel |
| Insulation Material | Foamed in Place Polyurethane |
| Shelf Material | Plastic Coated Steel |
| Shelf Load Capacity | 90 lbs. |

Electrical

| | |
|------------------------|------|
| Voltage | 120 |
| Amps | 11.1 |
| Hz | 60 |
| Phase | 1 |
| Electrical Cord Length | 96" |

Plan View

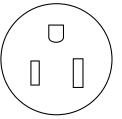
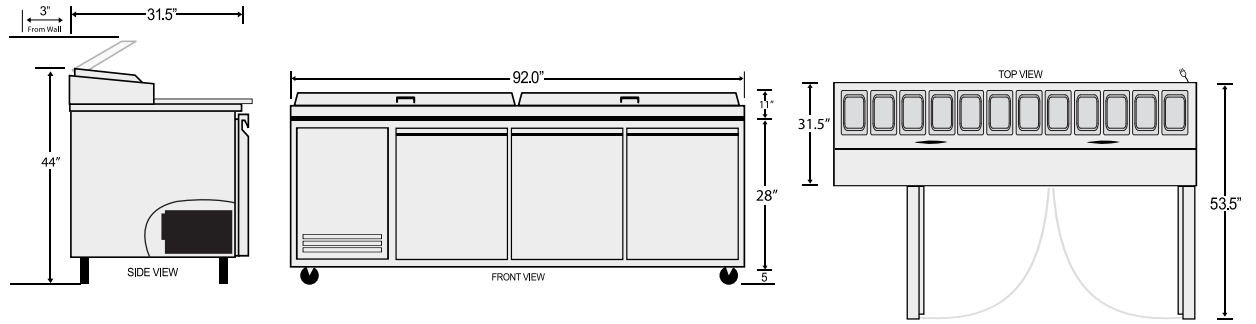

NEMA 5-15P



1 year
WARRANTY

Parts & Labor



5 year
WARRANTY

Compressor

All Avantco Refrigerators and Freezers are backed by a 1 year parts and labor warranty, with a 5 year warranty on the compressor. For warranty inquiries or service, first locate the serial number plate on the front of the unit, or inside the door jamb. Next, call 1-800-678-5517. Be sure to have the serial and model numbers available when contacting service technicians.