

# F Series Countertop Fryers



Easy-to-use controls and fast recovery times make the Avantco F series countertop fryers a perfect choice for French fries, chicken tenders, and more at snack bars, concession stands, or sandwich shops.



- Heavy duty stainless steel construction
- One tank holds 6 liters (1.5 gallons) of oil
- Heavy duty fryer basket(s) included
- Night cover included
- UL and CE Listed
- One year limited warranty

**F122 - 20 lb. Double  
Countertop Fryer**

**Features**

- Heavy duty stainless steel construction
- Each tank holds 6 liters of oil
- (2) Heavy duty fryer baskets included
- Separate tank temperature control switches
- Night cover included
- 120V
- UL & CE listed

**Description**

The Avantco F122 20 lb. twin pot countertop fryer is suitable for light duty applications such as delis, sandwich shops, and concession stands. With a 15-minute heat-up time, this fryer is ready to use in no time! Each removable tank has a capacity of 6 liters (1.5 gallons), and the unit can cook up to 20 lbs. of food per hour. Additionally, each tank has its own temperature switch with a range of 120 to 375 degrees Fahrenheit. You don't even have to use both sides, since each fryer has its own cord.

Handles are included on each tank for easy removal to dump the old oil. Additional accessories include a night cover for each tank, and 2 fryer baskets. The Avantco F122 countertop fryer requires a 120V electrical connection and is UL & CE listed.



**Technical Data**

Exterior Dimensions	21½"x 17"x 11½"
Tank/Pot Dimensions	9½"x 12"x 6"
Oil Capacity	12 liters (3 gallons)
Temperature Range	120° - 375° F
Voltage	120V
Cord Length	4.25'

20 lb. Double Countertop Fryer 120V

## Plan View

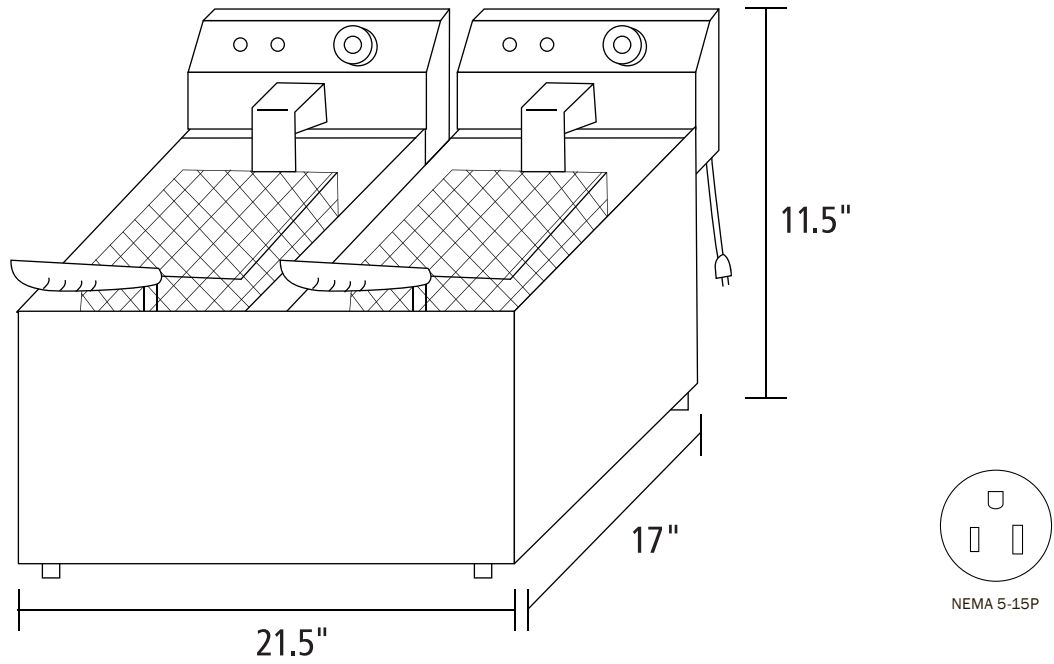

## Recommended Companion Product

**Tempest**  
DEEP FAT FRYER CLEANER

Tough on grease. Tough on carbon. Tempest deep fat fryer cleaner powder offers thorough boil out of encrusted grease and grime.