

# Single Burner Countertop Range

## ITEM NUMBER

#177EB100

## SPECIAL FEATURES

- Self-cleaning heating element
- Excellent for catering services and display cooking stations
- Lightweight and portable
- Cool-touch end panels
- Three adjustable Heat Settings give independent control

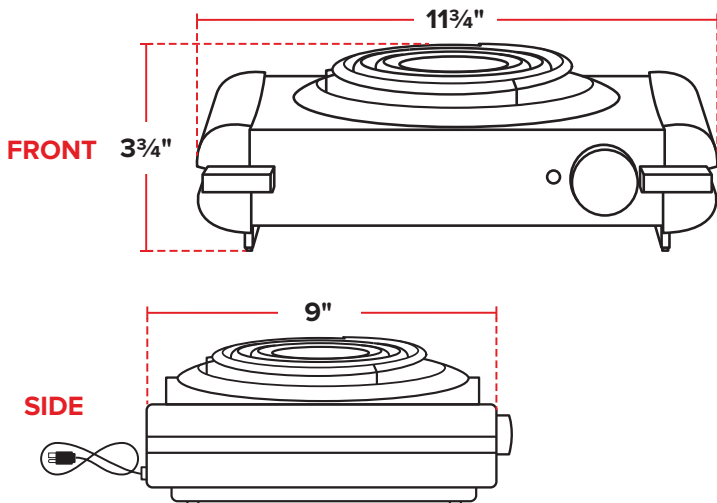
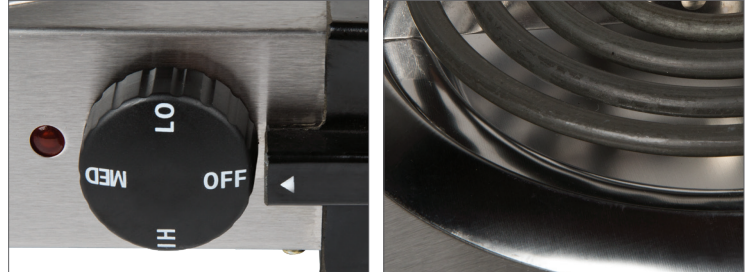

## TECHNICAL DATA

Dimensions	11 $\frac{3}{4}$ "W x 9"D x 3 $\frac{3}{4}$ "H
Number of Burners	1
Controls	Manual
Watts	1000W
Voltage	120V
Hertz	60
Phase	1



1-15P