

PRODUCT:

QUANTITY:

ITEM #:

### Designed Smart

#### Compact Design With High Output

- Fits in tight counter space and is available in a “large basket” capacity version (EF-30) or versatile “twin 15 lb.” version (EF-30NT).
- EF-30 and EF-30NT come standard with two full size baskets. Please specify if requesting twin 15 lb. baskets on EF-30NT.
- Reaches frying temperatures fast, and maintains heat levels from one load to the next.

#### Easy to Operate

- Yellow cycling light alerts operator that unit is ready for next batch of fries.
- Unit automatically shuts down if frying compound overheats.
- Stainless steel exterior is easy to wipe clean.



EF-30NT Countertop Electric Fryer

### Built Solid

#### Built to Last!

- Thick, stainless steel construction

#### Reliability backed by APW Wyott’s Warranty

- APW Wyott cooking equipment is backed by a 1-year limited warranty, and a 1-year on-site labor warranty.
- Certified by the following agencies:



### APW Wyott Design Features

- Stainless steel construction.
- 4” (10 cm) legs.
- Front panel permits easy servicing.
- Lift-out, one piece tank with carrying handles. Large foaming area above frying compound level. Insulating air pocket surrounds tank for improved temperature control.
- Swing up, pyrolytic heating elements with two-stage locking mechanism.
- Cold zone under heating elements reduces circulation of particles in frying compound.
- Front-located adjustable thermostat (200°F / 93°C to 400°F / 204°C) with on/off switch.
- High-limit protection control circuit breaker which automatically trips should frying compound overheat.
- Front panel yellow cycling light indicates that frying temperature has been reached.
- High temperature 392°F (200°C) internal wiring.
- Nickel-plated twin fry baskets with front hangers.

See reverse side for product specifications.

PRODUCT:

QUANTITY:

ITEM #:

Models:  EF-30 208V  EF-30 240V  EF-30NT 208V  EF-30NT 240V

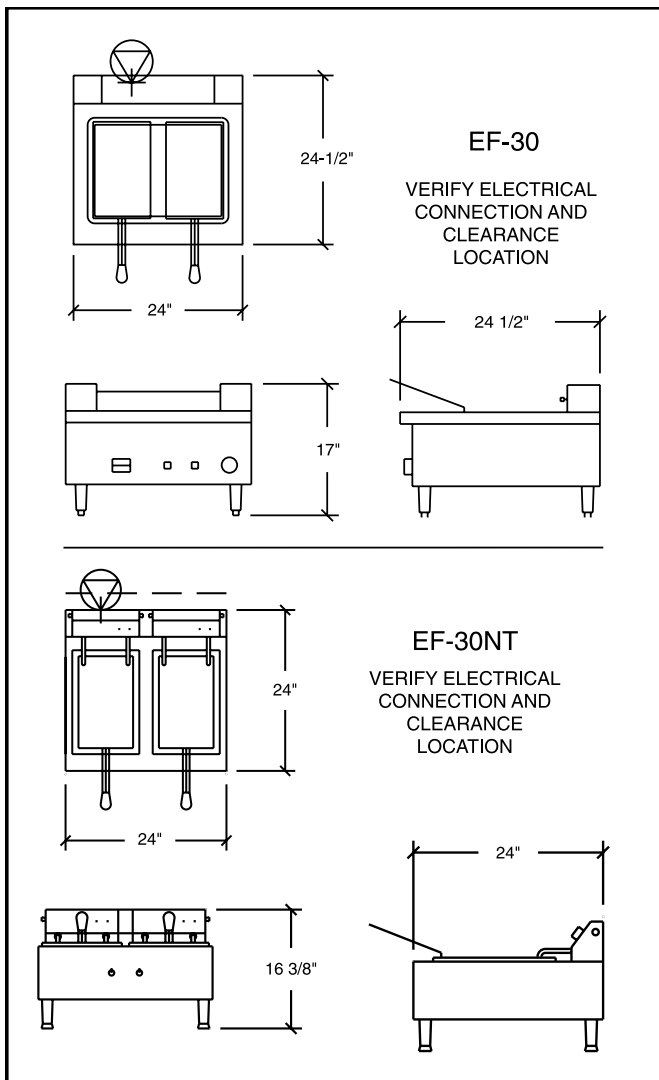

## PRODUCT SPECIFICATIONS

### Construction:

Heavy-duty stainless steel body. Fry baskets are constructed of nickel-plated steel. 4" adjustable chrome legs.

### Electrical Information:

Units are wired for hard wiring in the field.

### Electrical Specifications:

EF-30-208V: 208V, 12 KW, 57.7 Amps -1 Phase

208V, 12 KW, 50 Amps -3 Phase

EF-30-240V: 240V, 12 KW, 50 Amps -1 Phase

240V, 12 KW, 43.3 Amps -3 Phase

EF-30NT-208V: 208V, 8.56 KW, 41.2 Amps -1 Phase

EF-30NT-240V: 240V, 11.4 KW, 47.7 Amps -1 Phase

### Capacity:

EF-30: 30 lbs. (13.6). Produces up to 60 lbs. of raw-to-done potatoes per hour.

EF-30NT: 30 lbs. (13.6). Produces up to 60 lbs. of raw-to-done potatoes per hour.

### Basket Size:

Full Size 6 1/4" H x 7 1/4" W x 11 2/5" D

### Overall Dimensions:

EF-30: 17" H x 24" W x 24 1/2" D  
(43.2 cm x 61 cm x 62.2 cm)

EF-30NT: 16 3/8" H x 24" W x 24" D  
(41.6 cm x 61 cm x 61 cm)

### Shipping:

EF-30: 92 lbs. (41.8 kg)

EF-30NT: 75 lbs. (34 kg)

Freight Class: 85

FOB: Cheyenne, WY

\*APW Wyott reserves the right to modify specifications or discontinue models without incurring obligation.