

20•20ESG SERIES COMBITHERM® COMBIOVEN



- EcoSmart design uses less electricity and water than competitive models. Reduced energy setting further minimizes electricity use.
- Exclusive Gold-n-Brown™ features gives the operator the ability to achieve the ideal cooking environment for the ideal finish.

MODEL 20•20ESG WITH COMBITOUCH CONTROL
ROLL-IN PAN CART INCLUDED
CAPACITY OF FORTY (40) FULL-SIZE OR GN 1/1 PANS,
TWENTY (20) FULL-SIZE SHEET OR GN 2/1 PANS



- Expandable system to meet your specific requirements.
- Cook with the included product temperature probe (not included as standard on S-control models) or by time.
- Cooks with variable steam, convection heat, or a combination of both to roast, steam, bake, or oven-fry. Cooking speeds are increased by as much as 70% compared to conventional cooking methods.
- CombiClean® feature uses jets of water for fully automated cleaning. Use either commercial-strength CombiClean Tablets or Combitherm Cleaning Liquid Spray.
- Boiler-free flash-steam generation increases reliability by eliminating boiler maintenance and boiler heating element burnout. Steam levels are maintained without a water reservoir.
- Optional, CombiSmoker® oven with smoking technology smokes any product, hot or cold.
- **CombiTouch®**
 - Intuitive CombiTouch control is fully operable from the touch screen.
 - Store up to 250 recipes, each with up to 9 steps. CombiTouch comes standard with more than 100 preprogrammed recipes and photos.
 - Six precise and consistent Gold-n-Brown™ browning levels.
 - Multi-shelf Timers track cooking time of ten different food items in the same oven.
 - Advance reversing fan design provides excellent baking results and prevents excessive water and power consumption.

Provide Alto-Shaam Combitherm® floor-standing Model 20•20ESG flash-steam gas CombiOven designed with EcoSmart® technology for reduced energy and water usage and include operational modes for steam, convection, and a combination of steam and convection heat. Standard features to include patented automatic steam venting; Gold-n-Brown™ browning function and a self-adjusting, flush-mounted rotary door handle. Oven is to be constructed of 18 gauge stainless steel, include an attached spray hose with backflow preventer, cool-down function, automatic cleaning function, and four (4) adjustable legs. Each oven is to accommodate up to twenty (20) full-size sheet pans or forty (40) full-size hotel pans, include standard right-hand door hinging, and Roll-in pan cart with twenty (20) non-tilt support rails (21-1/16" (535mm) horizontal width between rails, and 2-5/8" (65mm) vertical spacing between rails), ten (10) stainless steel shelves, removable drip tray and cart handle.

- CombiTouch® Control:** includes six different browning levels; two-speed reversing fan with coordinated venting system, USB port for data access, quick-connect single-point internal product temperature probe in the oven interior.

- Deluxe Control:** includes a quick-connect single-point internal product temperature probe in the oven interior and programming capability with Rapid-Touch™ operational quick-keys.

- Standard Control:** includes a quick-connect single-point internal product temperature probe in the oven interior.

- S-Control:** with quick-connect single-point internal product temperature probe in the oven interior as an option.

FACTORY INSTALLED

- Electrical Choices
 - Specify voltage:
 - 120 1ph
 - 208-240 1ph*
 - 208-240 3ph
 - 380-415 3ph*
 - * Touch only
- Gas Type
 - Specify choice:
 - Natural
 - Propane
- Door Swing
 - Specify choice
 - Right-hand Door Hinging, standard
 - Recessed Door, optional increases oven width by 4" (102mm)
 - Alternate Burner Orifice - specify elevation for elevations higher than 2,000 feet (610m) above sea level
 - Smoking Function, optional (not available on 120V units)
- Probe
 - Specify choice
 - Multi-point, hard-wired temperature probe [5005678] - not available on ovens with S-Control
 - Single-point, removable temperature probe - included on Touch, Deluxe and Standard controls
 - S-Control oven without smoker [5011570]
 - S-Control oven with smoker [5011571]
- Security Devices for correctional facility use.
 - Base package: excludes temperature probe
 - Specify additional choices
 - Anti Entrapment Device [5011081]
 - Control Panel Security Cover [5012224]
 - Hasp Door Lock (padlocks not included) [5011079]
 - Tamper-Proof Screw Package for oven [5013923]
 - Seismic Feet Package [5011135]



20•20ESG SERIES COMBITHERM COMBIOVEN

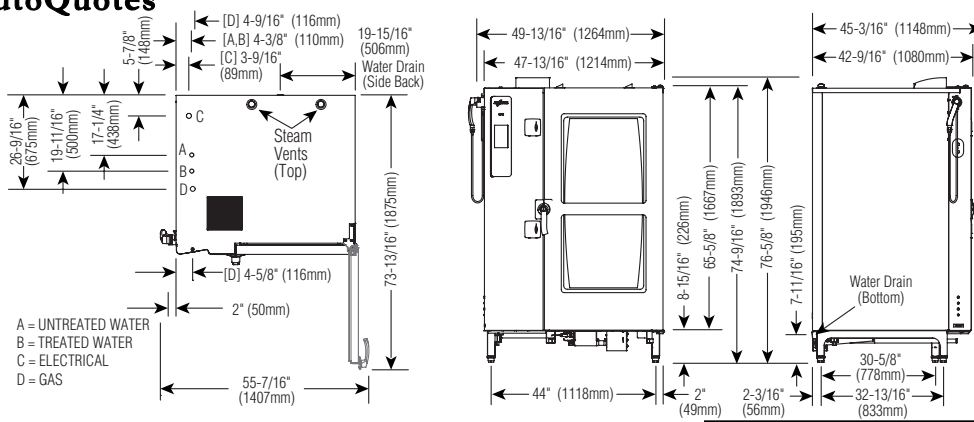

DIMENSIONS: H x W x D

EXTERIOR:

76-5/8" x 49-13/16" x 45-3/16" (1946mm x 1264mm x 1148mm)

EXTERIOR WITH RECESSED DOOR:

76-5/8" x 53-13/16" x 45-3/16" (1946mm x 1366mm x 1148mm)

INTERIOR:

54-15/16" x 25-1/4" x 33-7/8" (1395mm x 640mm x 860mm)

WATER REQUIREMENTS

TWO (2) COLD WATER INLETS - DRINKING QUALITY
ONE (1) TREATED WATER INLET: 3/4" NPT* * Can manifold off of one 3/4" line.
ONE (1) UNTREATED WATER INLET: 3/4" NPT*
LINE PRESSURE: 30 to 90 psi 2.8 to 6.2 bar
WATER DRAIN: 1-1/2" CONNECTION WITH A 2" MINIMUM AIR GAP INSTALLED AS CLOSE TO THE OVEN AS POSSIBLE

CLEARANCE REQUIREMENTS

LEFT 6" (152mm) **RECOMMENDED SERVICE ACCESS:** 18" (457mm)
 20" (508mm) **FROM HEAT PRODUCING EQUIPMENT**
RIGHT 4" (102mm) **TOP:** 20" (508mm) **FOR AIR MOVEMENT**
BACK 4" (102mm) **BOTTOM:** 5-1/8" (130mm) **FOR LEGS**

GAS REQUIREMENTS (TYPE MUST BE SPECIFIED ON ORDER)

CONNECTED ENERGY LOAD: 190,000 Btu / hr (Natural Gas)
 170,000 Btu / hr (Propane)
HOOK-UP: 3/4" NPT
MINIMUM CONNECTED PRESSURE: 5.5" W.C. (Natural Gas)
 9" W.C. (Propane)
MAXIMUM CONNECTED PRESSURE: 14" W.C.

WATER QUALITY MINIMUM STANDARDS

USING A WATER SUPPLY NOT MEETING ALTO-SHAAM'S MINIMUM WATER QUALITY STANDARDS WILL VOID THIS WARRANTY. It is the responsibility of the purchaser to ensure that incoming water supply is compliant with the specifications listed through adequate treatment measures. Installation of the CombiGuard™ Water Filtration System is recommended, but this system may not address all water quality issues present.

Contaminant	Inlet Water Requirements (untreated water)
Free Chlorine	Less than 0.1 ppm (mg/L)
Hardness	Less than 3 gpg (52 ppm)
Chloride	Less than 30 ppm (mg/L)
pH	7.0 to 8.5
Alkalinity	Less than 50 ppm (mg/L)
Silica	Less than 12 ppm (mg/L)
Total Dissolved Solids (tds)	Less than 60 ppm

ELECTRICAL (DEDICATED CIRCUIT REQUIRED)

MODEL	VOLTAGE	PH	HZ	AMPS	kW	AWG	CORD & PLUG	CombiSmoker® Additional kW
20•20ESG Touch	120	1	60	9.0	1.04	AWG 12	NEMA L5-30P, 30A, 125V Plug	SK NOT AVAILABLE
	208 - 240	1	60	5.0	1.04	AWG 12	no cord or plug	+ .7 kw
	208 - 240	3	60	5.0/ph	1.04	AWG 12	no cord or plug	+ .7 kw
	380 - 415	3	50	2.0/ph	1.44	AWG 12	Bare End, 3 Wire + ground	+ .7 kw
20•20ESG	120	1	60	12.2	1.40	AWG 12	no cord or plug	SK NOT AVAILABLE
	208 - 240	3	60	4.27/ph	1.54	AWG 12	Bare End, 3 Wire + ground	+ .7 kw

WEIGHT

NET 900 lb est (408 kg)
SHIP 1227 lb (557 kg)
CRATE DIMENSIONS: (L x W x H)
 54" x 49" x 85"
 (1374 x 1245 x 2159mm)

CAPACITY

FULL-SIZE PANS: 20" x 12" x 2-1/2"
 Forty (40)
GN 1/1: 530 x 325 x 65mm
 Forty (40)
GN 2/1: 650 x 530 x 65mm
 Twenty (20)
FULL-SIZE SHEET PANS:* 18" x 26" x 1"
 Twenty (20)
ON WIRE SHELVES ONLY

480 lb (218 kg) MAXIMUM

VOLUME MAXIMUM: 300 quarts (380 liters)

*ADDITIONAL WIRE SHELVES REQUIRED FOR MAXIMUM CAPACITY

20•20ESG SERIES COMBITHERM® COMBIOVEN



CombiTouch

Deluxe

Standard

S-Control



Steam Mode

- Automatic steaming at 212°F (100°C).
- Quick steaming.
 - Touch — 213°F to 250°F (101°C to 121°C).
 - Deluxe, Standard, S-Control — 213°F to 248°F (101°C to 120°C).
- Low temperature steaming for poaching or proofing.
 - Touch — 85°F and 211°F (29°C and 99°C).
 - Deluxe, Standard, S-Control — 86°F and 211°F (30°C and 99°C).



Combination Mode

- Combines steam and convection modes for faster production and better moisture retention.
- Improves yield, quality and shelf life.
- Automatic humidity control.
 - Touch — 212°F to 485°F (100°C to 252°C).
 - Deluxe, Standard, S-Control — 212°F to 482°F (100°C to 250°C).



Convection Mode

- Cooking, roasting, baking and finishing applications.
 - Touch — 85°F to 485°F (29°C to 252°C).
 - Deluxe, Standard, S-Control — 86°F to 482°F (30°C to 250°C).



Retherm Mode

- Bulk food or plated meal reheating with automatic steam injection.
 - Touch — 245°F to 320°F (118°C to 160°C).
 - Deluxe, Standard, S-Control — 248°F to 320°F (120°C to 160°C).
- Automatic humidity control.



Gold-n-Brown™

- Gold-n-Brown vents just the right amount of humidity in the oven cavity for perfect browning.
 - Touch — Six levels of Gold-n-Brown are featured.



Moisture Injection

- A quick burst of moisture can be added with a touch of a button at any time when cooking in the convection mode.



HACCP Data Access (CombiTouch only)

- Records cooking mode, time and temperature completed within a two week time period. The information is captured in a text format and can be downloaded to a USB device.



CombiSmoker® (option)

- Smoke any product, hot or cold, utilizing real wood chips.
- Functions in both combination and convection mode.
- Function can be programmed into operating procedure.
- Sample bag of wood chips included.

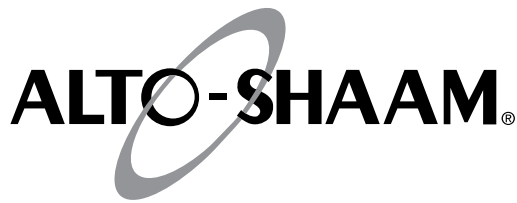

20•20ESG SERIES COMBITHERM COMBIOVEN



OPTIONS & ACCESSORIES	
<input type="checkbox"/> CHICKEN GREASE TRAY WITH DRAIN: 1-1/2" (38mm) DEEP	4758
CHICKEN ROASTING RACKS:	
<input type="checkbox"/> 6 CHICKEN CAPACITY — FITS FULL-SIZE PAN: 10 RACKS PER OVEN	SH-23000
<input type="checkbox"/> 8 CHICKEN CAPACITY — FITS FULL-SIZE PAN: 12 RACKS PER OVEN	SH-23619
<input type="checkbox"/> 10 CHICKEN CAPACITY — FITS IN SIDE RACKS: 12 RACKS PER OVEN	SH-22634
<input type="checkbox"/> COMBIGUARD™ BWS BLENDED WATER SYSTEM (INCLUDES 50 GALLON TANK, 1 MEMBRANE & 3 FILTERS)	FI-28727
<input type="checkbox"/> COMBIGUARD™ BWS REPLACEMENT FILTER CARTRIDGE AMS-QT	FI-29316
<input type="checkbox"/> COMBIGUARD™ BWS REPLACEMENT FILTER CARTRIDGE SCLX2-Q	FI-29317
<input type="checkbox"/> COMBIGUARD™ BWS REPLACEMENT PREFILTER FILTER CARTRIDGE CTO-Q	FI-29318
<input type="checkbox"/> COMBIGUARD™ 20 TRIPLE-GUARD WATER FILTRATION SYSTEM (INCLUDES 1 CARTRIDGE)	FI-28728
<input type="checkbox"/> COMBIGUARD™ 20 TRIPLE-GUARD REPLACEMENT FILTER	FI-28744
<input type="checkbox"/> COMBITHERM CLEANING LIQUID — SPECIALLY FORMULATED FOR COMBITHERM OVENS ➔ TWELVE (12) CONTAINERS/CASE, 1 QUART (C. 1 LITER) EACH [SPECIAL HANDLING REQUIRED]	CE-24750
<input type="checkbox"/> COMBICLEAN® TABLETS — SPECIALLY FORMULATED FOR COMBITHERM OVENS ➔ 90 PACKETS EACH CONTAINER	CE-28892
<input type="checkbox"/> EXTENDED ONE-YEAR WARRANTY	CONTACT FACTORY
<input type="checkbox"/> FRY BASKET, 12" x 20" (325mm x 530mm)	BS-26730
<input type="checkbox"/> GAS LINE QUICK DISCONNECT KIT	CR-33543
<input type="checkbox"/> GRILLING GRATE, 12" x 20" (325mm x 530mm)	SH-26731
<input type="checkbox"/> PREHEAT SEALING STRIP (TO PREHEAT RIGHT HAND UNITS WITHOUT ROLL-IN TROLLEY)	1010739
<input type="checkbox"/> PREHEAT SEALING STRIP (TO PREHEAT RECESSED DOOR UNITS WITHOUT ROLL-IN TROLLEY)	1010752
<input type="checkbox"/> PROBE, SOUS VIDE	PR-34747
<input type="checkbox"/> ROLL-IN PAN CART (H X W X D): 65-11/16" x 28-1/8" x 33-5/16" (1668mm x 714mm x 846mm) INTERCHANGEABLE WITH 20•20 COMBIMATE HOLDING CABINET AND QC-100 QUICKCHILLER	UN-27970
<input type="checkbox"/> ROLL-IN PAN CART — CORRECTIONAL INSTITUTION (H X W X D): 65-11/16" x 28-1/8" x 33-5/16" (1668mm x 714mm x 846mm) INCLUDES TAMPER-PROOF SCREWS AND WELDED HANDLE INTERCHANGEABLE WITH 20•20 COMBIMATE HOLDING CABINET AND QC-100 QUICKCHILLER	5010642
ROLL-IN PLATE CART (H X W X D) INTERCHANGEABLE WITH 20•20 COMBIMATE HOLDING CABINET:	
<input type="checkbox"/> 108 PLATE CAPACITY – 65-1/2" x 30-5/16" x 39-9/16" (1663mm x 770mm x 1004mm) 2-11/16" (69mm) SPACING	UN-27971
<input type="checkbox"/> 108 PLATE CAPACITY – 65-1/2" x 30-5/16" x 39-9/16" (1663mm x 770mm x 1004mm) 2-11/16" (69mm) SPACING – CORRECTIONAL INSTITUTION	5009899
<input type="checkbox"/> 78 PLATE CAPACITY – 65-1/2" x 30-5/16" x 39-9/16" (1663mm x 770mm x 1004mm) 3-1/2" (89mm) SPACING	UN-28311
<input type="checkbox"/> SCALE FREE™ (CITRUS BASED, NON-CORROSIVE DELIMING PRODUCT)	CE-27889
<input type="checkbox"/> SERVICE START-UP CHECK AVAILABLE THROUGH AN ALTO-SHAAM FASTEAM CENTER	SPECIFY AS REQUIRED
<input type="checkbox"/> SHELF, STAINLESS STEEL WIRE	SH-22473
<input type="checkbox"/> THERMOBAG (COVER FOR ROLL-IN TROLLEY)	BL-29128
WOOD CHIPS — BULK PACK 20 lb (9 kg)	
<input type="checkbox"/> ➔ Apple..... WC-22543	<input type="checkbox"/> ➔ Cherry..... WC-22541
<input type="checkbox"/> ➔ Hickory.....WC-2829	<input type="checkbox"/> ➔ Maple..... WC-22545