

12•18ESG SERIES COMBITHERM® COMBIOVEN



- EcoSmart design uses less electricity and water than competitive models. Reduced energy setting further minimizes electricity use.
- Exclusive Gold-n-Brown™ features gives the operator the ability to achieve the ideal cooking environment for the ideal finish.

- Expandable system to meet your specific requirements.
- Cook with the included product temperature probe (not included as standard on S-control models) or by time.
- Cooks with variable steam, convection heat, or a combination of both to roast, steam, bake, or oven-fry. Cooking speeds are increased by as much as 70% compared to conventional cooking methods.
- CombiClean® feature uses jets of water for fully automated cleaning. Use either commercial-strength CombiClean Tablets or Combitherm Cleaning Liquid Spray.
- Boiler-free flash-steam generation increases reliability by eliminating boiler maintenance and boiler heating element burnout. Steam levels are maintained without a water reservoir.
- Optional, CombiSmoker® oven with smoking technology smokes any product, hot or cold.
- **CombiTouch®**
 - Intuitive CombiTouch control is fully operable from the touch screen.
 - Store up to 250 recipes, each with up to 9 steps. CombiTouch comes standard with more than 100 preprogrammed recipes and photos.
 - Six precise and consistent Gold-n-Brown™ browning levels.
 - Multi-shelf Timers track cooking time of ten different food items in the same oven.
 - Advance reversing fan design provides excellent baking results and prevents excessive water and power consumption.

MODEL 12•18ESG WITH COMBITOUCH CONTROL
CAPACITY OF TWENTY-FOUR (24) FULL-SIZE OR GN 1/1 PANS,
TWELVE (12) FULL-SIZE SHEET OR GN 2/1 PANS



Provide Alto-Shaam Combitherm® counter-top Model 12•18ESG flash-steam gas CombiOven designed with EcoSmart® technology for reduced energy and water usage and include operational modes for steam, convection, and a combination of steam and convection heat. Standard features to include patented automatic steam venting; Gold-n-Brown™ browning function and a self-adjusting, flush-mounted rotary door handle. Oven is to be constructed of 18 gauge stainless steel, include an attached spray hose with backflow preventer, cool-down function, automatic cleaning function, and four (4) adjustable legs. Each oven is to accommodate up to 12 full-size sheet pans or 24 full-size hotel pans, include standard right-hand door hinging, twelve (12) non-tilt support rails (21-1/16" (535mm) horizontal width between rails, and 2-5/8" (65mm) vertical spacing between rails), and six (6) stainless steel shelves.

- CombiTouch® Control:** includes six different browning levels; two-speed reversing fan with coordinated venting system, USB port for data access, quick-connect single-point internal product temperature probe in the oven interior.
- Deluxe Control:** includes a quick-connect single-point internal product temperature probe in the oven interior and programming capability with Rapid-Touch™ operational quick-keys.
- Standard Control:** includes a quick-connect single-point internal product temperature probe in the oven interior.
- S-Control:** with quick-connect single-point internal product temperature probe in the oven interior as an option.

FACTORY INSTALLED

- Electrical Choices
 - Specify voltage:
 - 120 1ph
 - 208-240 1ph*
 - 208-240 3ph
 - * Touch only
- Gas Type
 - Specify choice:
 - Natural
 - Propane
- Door Swing
 - Specify choice
 - Right-hand Door Hinging, standard
 - Recessed Door, optional increases oven width by 4" (102mm)
 - Alternate Burner Orifice - specify elevation for elevations higher than 2,000 feet (610m) above sea level
 - Smoking Function, optional
- Probe
 - Specify choice
 - Multi-point, hard-wired temperature probe [5005678] - not available on ovens with S-Control
 - Single-point, removable temperature probe - included on Touch, Deluxe and Standard controls
 - S-Control oven without smoker [5011570]
 - S-Control oven with smoker [5011571]
- Security Devices for correctional facility use.
 - Base package: excludes temperature probe
 - Specify additional choices
 - Anti Entrapment Device [5011081]
 - Control Panel Security Cover [5012224]
 - Hasp Door Lock (padlocks not included) [5011079]
 - Tamper-Proof Screw Package for oven [5013922]
 - Seismic Feet Package [5011135]



12•18ESG SERIES COMBITHERM COMBIOVEN

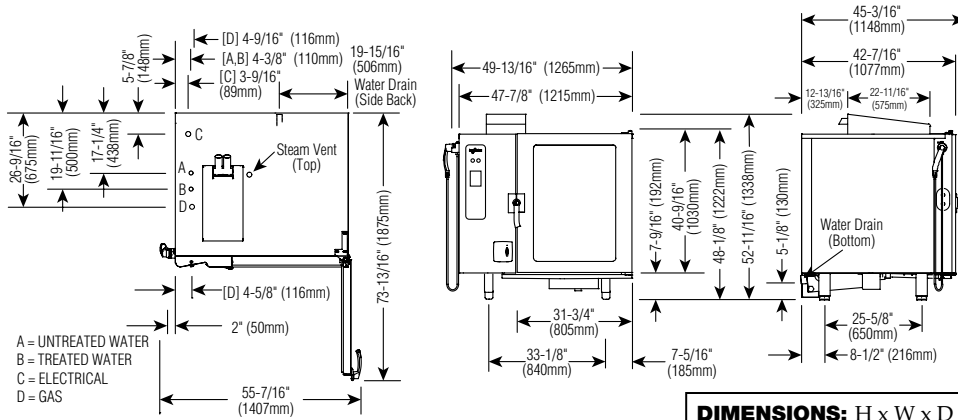

DIMENSIONS: H x W x D
EXTERIOR: 52-11/16" x 49-13/16" x 45-3/16" (1338mm x 1265mm x 1148mm)
EXTERIOR WITH RECESSED DOOR: 52-11/16" x 53-13/16" x 45-3/16" (1338mm x 1367mm x 1148mm)
INTERIOR: 33-7/8" x 25-1/4" x 33-7/8" (860mm x 640mm x 860mm)

WATER REQUIREMENTS	WATER QUALITY MINIMUM STANDARDS																																																			
<p>TWO (2) COLD WATER INLETS - DRINKING QUALITY</p> <p>ONE (1) TREATED WATER INLET: 3/4" NPT* * Can manifold off of one 3/4" line.</p> <p>ONE (1) UNTREATED WATER INLET: 3/4" NPT*</p> <p>LINE PRESSURE: 30 to 90 psi 2.8 to 6.2 bar</p> <p>WATER DRAIN: 1-1/2" CONNECTION WITH A 2" MINIMUM AIR GAP INSTALLED AS CLOSE TO THE OVEN AS POSSIBLE</p>	<p>USING A WATER SUPPLY NOT MEETING ALTO-SHAAM'S MINIMUM WATER QUALITY STANDARDS WILL VOID THIS WARRANTY.</p> <p>It is the responsibility of the purchaser to ensure that incoming water supply is compliant with the specifications listed through adequate treatment measures. Installation of the CombiGuard™ Water Filtration System is recommended, but this system may not address all water quality issues present.</p>																																																			
CLEARANCE REQUIREMENTS	Contaminant Inlet Water Requirements (untreated water)																																																			
<p>LEFT 6" (152mm) RECOMMENDED SERVICE ACCESS: 18" (457mm)</p> <p>20" (508mm) FROM HEAT PRODUCING EQUIPMENT</p> <p>RIGHT 4" (102mm) TOP: 20" (508mm) FOR AIR MOVEMENT</p> <p>BACK 4" (102mm) BOTTOM: 5-1/8" (130mm) FOR LEGS</p> <p>COUNTER-TOP INSTALLATIONS MUST MAINTAIN 4" (102mm) MINIMUM CLEARANCE FROM COUNTER SURFACE</p>	<p>Free Chlorine Less than 0.1 ppm (mg/L)</p> <p>Hardness Less than 3 gpg (52 ppm)</p> <p>Chloride Less than 30 ppm (mg/L)</p> <p>pH 7.0 to 8.5</p> <p>Alkalinity Less than 50 ppm (mg/L)</p> <p>Silica Less than 12 ppm (mg/L)</p> <p>Total Dissolved Solids (tds) Less than 60 ppm</p>																																																			
GAS REQUIREMENTS (TYPE MUST BE SPECIFIED ON ORDER)	INSTALLATION REQUIREMENTS																																																			
<p>CONNECTED ENERGY LOAD: 105,000 Btu / hr</p> <p>HOOK-UP: 3/4" NPT</p> <p>MINIMUM CONNECTED PRESSURE: 5.5" W.C. (Natural Gas)</p> <p>9" W.C. (Propane)</p> <p>MAXIMUM CONNECTED PRESSURE: 14" W.C.</p>	<ul style="list-style-type: none"> Oven must be installed level. Hood installation is required. Water supply shut-off valve and back-flow preventer when required by local code. Alternate burner orifice is required for installation sites at elevations of 2,000 feet (610m) above sea level. 																																																			
ELECTRICAL (DEDICATED CIRCUIT REQUIRED)	CombiSmoker®																																																			
<table border="1"> <thead> <tr> <th>MODEL</th> <th>VOLTAGE</th> <th>PH</th> <th>HZ</th> <th>AMPS</th> <th>KW</th> <th>AWG</th> <th>CORD & PLUG</th> <th>Additional kW</th> </tr> </thead> <tbody> <tr> <td rowspan="3">12•18ESG Touch</td> <td>120</td> <td>1</td> <td>60</td> <td>5.0</td> <td>.58</td> <td>AWG 12</td> <td>NEMA 5-20P, 20A, 125V Plug</td> <td>+ .05 kw</td> </tr> <tr> <td>208 - 240</td> <td>1</td> <td>60</td> <td>5.0</td> <td>1.04</td> <td>AWG 12</td> <td>no cord or plug</td> <td>+ .05 kw</td> </tr> <tr> <td>208 - 240</td> <td>3</td> <td>60</td> <td>5.0/ph</td> <td>1.04</td> <td>AWG 12</td> <td>no cord or plug</td> <td>+ .07 kw</td> </tr> <tr> <td rowspan="2">12•18ESG</td> <td>120</td> <td>1</td> <td>60</td> <td>6.0</td> <td>.69</td> <td>AWG 12</td> <td>NEMA 5-20P, 20A, 125V Plug</td> <td>+ .05 kw</td> </tr> <tr> <td>208 - 240</td> <td>3</td> <td>60</td> <td>3.2/ph</td> <td>1.14</td> <td>AWG 12</td> <td>no cord or plug</td> <td>+ .07 kw</td> </tr> </tbody> </table>	MODEL	VOLTAGE	PH	HZ	AMPS	KW	AWG	CORD & PLUG	Additional kW	12•18ESG Touch	120	1	60	5.0	.58	AWG 12	NEMA 5-20P, 20A, 125V Plug	+ .05 kw	208 - 240	1	60	5.0	1.04	AWG 12	no cord or plug	+ .05 kw	208 - 240	3	60	5.0/ph	1.04	AWG 12	no cord or plug	+ .07 kw	12•18ESG	120	1	60	6.0	.69	AWG 12	NEMA 5-20P, 20A, 125V Plug	+ .05 kw	208 - 240	3	60	3.2/ph	1.14	AWG 12	no cord or plug	+ .07 kw	
MODEL	VOLTAGE	PH	HZ	AMPS	KW	AWG	CORD & PLUG	Additional kW																																												
12•18ESG Touch	120	1	60	5.0	.58	AWG 12	NEMA 5-20P, 20A, 125V Plug	+ .05 kw																																												
	208 - 240	1	60	5.0	1.04	AWG 12	no cord or plug	+ .05 kw																																												
	208 - 240	3	60	5.0/ph	1.04	AWG 12	no cord or plug	+ .07 kw																																												
12•18ESG	120	1	60	6.0	.69	AWG 12	NEMA 5-20P, 20A, 125V Plug	+ .05 kw																																												
	208 - 240	3	60	3.2/ph	1.14	AWG 12	no cord or plug	+ .07 kw																																												
WEIGHT	CAPACITY																																																			
<p>NET 573 lb est (260 kg)</p> <p>SHIP 789 lb (358 kg)</p> <p>CRATE DIMENSIONS: (L x W x H)</p> <p>45" x 53" x 52"</p> <p>(1143 x 1346 x 1321mm)</p>	<table border="1"> <tr> <td>FULL-SIZE PANS:</td> <td>20" x 12" x 2-1/2"</td> <td>Twenty-four (24)</td> </tr> <tr> <td>GN 1/1:</td> <td>530 x 325 x 65mm</td> <td>Twenty-four (24)</td> </tr> <tr> <td>GN 2/1:</td> <td>650 x 530 x 65mm</td> <td>Twelve (12)</td> </tr> <tr> <td>FULL-SIZE SHEET PANS:*</td> <td>18" x 26" x 1"</td> <td>Twelve (12)</td> </tr> <tr> <td>ON WIRE SHELVES ONLY</td> <td></td> <td></td> </tr> <tr> <td colspan="3" style="text-align: center;">288 lb (131 kg) MAXIMUM</td> </tr> <tr> <td colspan="3" style="text-align: center;">VOLUME MAXIMUM: 180 quarts (228 liters)</td> </tr> </table>	FULL-SIZE PANS:	20" x 12" x 2-1/2"	Twenty-four (24)	GN 1/1:	530 x 325 x 65mm	Twenty-four (24)	GN 2/1:	650 x 530 x 65mm	Twelve (12)	FULL-SIZE SHEET PANS:*	18" x 26" x 1"	Twelve (12)	ON WIRE SHELVES ONLY			288 lb (131 kg) MAXIMUM			VOLUME MAXIMUM: 180 quarts (228 liters)																																
FULL-SIZE PANS:	20" x 12" x 2-1/2"	Twenty-four (24)																																																		
GN 1/1:	530 x 325 x 65mm	Twenty-four (24)																																																		
GN 2/1:	650 x 530 x 65mm	Twelve (12)																																																		
FULL-SIZE SHEET PANS:*	18" x 26" x 1"	Twelve (12)																																																		
ON WIRE SHELVES ONLY																																																				
288 lb (131 kg) MAXIMUM																																																				
VOLUME MAXIMUM: 180 quarts (228 liters)																																																				

*ADDITIONAL WIRE SHELVES REQUIRED FOR MAXIMUM CAPACITY

12•18ESG SERIES COMBITHERM® COMBIOVEN



CombiTouch



Deluxe



Standard



S-Control



Steam Mode

- Automatic steaming at 212°F (100°C).
- Quick steaming.
 - Touch — 213°F to 250°F (101°C to 121°C).
 - Deluxe, Standard, S-Control — 213°F to 248°F (101°C to 120°C).
- Low temperature steaming for poaching or proofing.
 - Touch — 85°F and 211°F (29°C and 99°C).
 - Deluxe, Standard, S-Control — 86°F and 211°F (30°C and 99°C).



Combination Mode

- Combines steam and convection modes for faster production and better moisture retention.
- Improves yield, quality and shelf life.
- Automatic humidity control.
 - Touch — 212°F to 485°F (100°C to 252°C).
 - Deluxe, Standard, S-Control — 212°F to 482°F (100°C to 250°C).



Convection Mode

- Cooking, roasting, baking and finishing applications.
 - Touch — 85°F to 485°F (29°C to 252°C).
 - Deluxe, Standard, S-Control — 86°F to 482°F (30°C to 250°C).



Retherm Mode

- Bulk food or plated meal reheating with automatic steam injection.
 - Touch — 245°F to 320°F (118°C to 160°C).
 - Deluxe, Standard, S-Control — 248°F to 320°F (120°C to 160°C).
- Automatic humidity control.



Gold-n-Brown™

- Gold-n-Brown vents just the right amount of humidity in the oven cavity for perfect browning.
 - Touch — Six levels of Gold-n-Brown are featured.



Moisture Injection

- A quick burst of moisture can be added with a touch of a button at any time when cooking in the convection mode.



HACCP Data Access (CombiTouch only)

- Records cooking mode, time and temperature completed within a two week time period. The information is captured in a text format and can be downloaded to a USB device.



CombiSmoker® (option)

- Smoke any product, hot or cold, utilizing real wood chips.
- Functions in both combination and convection mode.
- Function can be programmed into operating procedure.
- Sample bag of wood chips included.

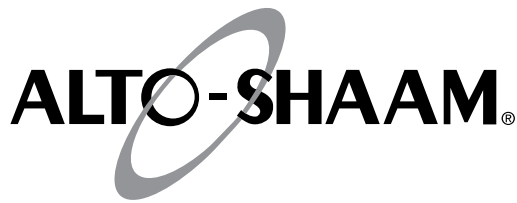

12•18ESG SERIES COMBITHERM COMBIOVEN



OPTIONS & ACCESSORIES		
<input type="checkbox"/>	CHICKEN GREASE TRAY WITH DRAIN: 1-1/2" (38mm) DEEP	4758
<input type="checkbox"/>	CHICKEN GREASE TRAY WITH DRAIN: 2-3/4" (70mm) DEEP	14475
CHICKEN ROASTING RACKS:		
<input type="checkbox"/>	6 CHICKEN CAPACITY — FITS FULL-SIZE PAN: 6 RACKS PER OVEN	SH-23000
<input type="checkbox"/>	8 CHICKEN CAPACITY — FITS FULL-SIZE PAN: 8 RACKS PER OVEN	SH-23619
<input type="checkbox"/>	10 CHICKEN CAPACITY — FITS IN SIDE RACKS: 8 RACKS PER OVEN	SH-22634
<input type="checkbox"/>	COMBIGUARD™ BWS BLENDED WATER SYSTEM (INCLUDES 50 GALLON TANK, 1 MEMBRANE & 3 FILTERS)	FI-28727
<input type="checkbox"/>	COMBIGUARD™ BWS REPLACEMENT FILTER CARTRIDGE AMS-QT	FI-29316
<input type="checkbox"/>	COMBIGUARD™ BWS REPLACEMENT FILTER CARTRIDGE SCLX2-Q	FI-29317
<input type="checkbox"/>	COMBIGUARD™ BWS REPLACEMENT PREFILTER FILTER CARTRIDGE CTO-Q	FI-29318
<input type="checkbox"/>	COMBIGUARD™ 20 TRIPLE-GUARD WATER FILTRATION SYSTEM (INCLUDES 1 CARTRIDGE)	FI-28728
<input type="checkbox"/>	COMBIGUARD™ 20 TRIPLE-GUARD REPLACEMENT FILTER	FI-28744
<input type="checkbox"/>	COMBITHERM CLEANING LIQUID — SPECIALLY FORMULATED FOR COMBITHERM OVENS ➔ TWELVE (12) CONTAINERS/CASE, 1 QUART (C. 1 LITER) EACH [SPECIAL HANDLING REQUIRED]	CE-24750
<input type="checkbox"/>	COMBICLEAN® TABLETS — SPECIALLY FORMULATED FOR COMBITHERM OVENS ➔ 90 PACKETS EACH CONTAINER	CE-28892
<input type="checkbox"/>	EXTENDED ONE-YEAR WARRANTY	CONTACT FACTORY
<input type="checkbox"/>	FRY BASKET, 12" x 20" (325mm x 530mm)	BS-26730
<input type="checkbox"/>	GAS LINE QUICK DISCONNECT KIT	CR-33543
<input type="checkbox"/>	GRILLING GRATE, 12" x 20" (325mm x 530mm)	SH-26731
<input type="checkbox"/>	HEAT SHIELD ASSEMBLY	5014495
<input type="checkbox"/>	PROBE, SOUS VIDE	PR-34747
<input type="checkbox"/>	SCALE FREE™ (CITRUS BASED, NON-CORROSIVE DELIMING PRODUCT)	CE-27889
<input type="checkbox"/>	SERVICE START-UP CHECK AVAILABLE THROUGH AN ALTO-SHAAM FASTEAM CENTER	SPECIFY AS REQUIRED
<input type="checkbox"/>	SHELF, STAINLESS STEEL WIRE	SH-22584
STAND, STAINLESS STEEL (H X W X D):		
<input type="checkbox"/>	➔ STATIONARY 14-3/16" x 47-7/8" x 37-1/16" (359mm x 1215mm x 941mm)	5007855
<input type="checkbox"/>	➔ MOBILE 17-3/4" x 47-7/8" x 37-1/16" (451mm x 1215mm x 941mm)	5008551
WOOD CHIPS — BULK PACK 20 lb (9 kg)		
<input type="checkbox"/>	➔ Apple..... WC-22543	<input type="checkbox"/>
<input type="checkbox"/>	➔ Cherry..... WC-22541	<input type="checkbox"/>
<input type="checkbox"/>	➔ Hickory..... WC-2829	<input type="checkbox"/>
<input type="checkbox"/>	➔ Maple..... WC-22545	