



 **ANVIL**

HOT FOOD MERCHANDISER

HOT FOOD MERCHANDISER ELECTRIC

"Anvil's hot food merchandisers are a great way to present your food and keep it warm. Suitable for all types of foodstuffs."

APPLICATION

- ENHANCES FOOD PRESENTATIONS
- KEEPS FOOD AT THE RIGHT TEMPERATURE AND HUMIDITY
- ADJUSTABLE 3 TIER MERCHANDISER DISPLAY SHELF
- CONVENIENT ACCESSIBILITY WITH FRONT & REAR SLIDING DOORS

CONSTRUCTION

- EASY TO CLEAN
- COOL TOUCH DUE TO DOUBLE SKIN STAINLESS STEEL CONSTRUCTION
- CAN OPEN FROM THE FRONT FOR SELF SERVICE

HEATING

- VARIABLE HEAT CONTROL WITH HUMIDITY
- SPECIFICALLY DESIGNED HEAT BAFFLE TO ENSURE EVEN TEMPERATURE DISTRIBUTION
- THERMOSTATICALLY CONTROLLED HEATER



Anvil reserves the right, without notice, to make changes and revisions to product specifications, materials and design, which in our opinion, will provide better performance, durability and efficiency.

QUALITY  **GUARANTEE**

ALL ANVIL EQUIPMENT COMES WITH A ONE YEAR WARRANTY ON COMPONENTS AND DEFECTIVE WORKMANSHIP



NOTE:

When viewing the appliance from the front in its usual operating position, the width (W) of the product is the total distance from left to right ; the depth (D) of the product is the total distance from front to back ; the height (H) is the total distance from the bottom of the product to the top

**HOT FOOD
MERCHANDISER
ELECTRIC**

MODELS:
FMA7026
FMA7036
FMA7048

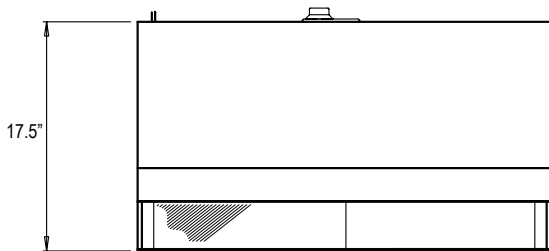
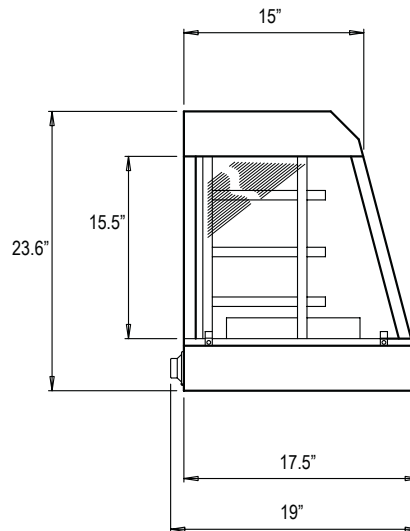
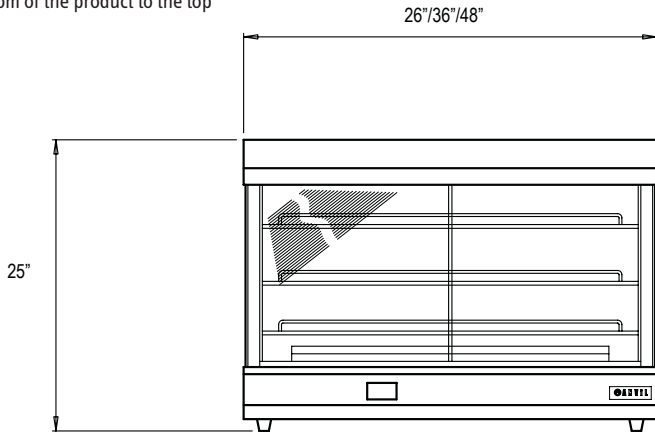

NEMA 5015P
110V

DESCRIPTION	HOT FOOD MERCHANDISER	HOT FOOD MERCHANDISER	HOT FOOD MERCHANDISER
MODELS	FMA7026	FMA7036	FMA7048
WIDTH	26"	36"	48"
VOLTAGE	110	110	110
POWER (Kw)	1.5Kw	1.5Kw	1.5Kw
DIMENSIONS (in) (W x D x H)	26 x 17.5 x 25	36 x 17.5 x 25	48 x 17.5 x 25
BOX DIMNS (in) (W x D x H)	30 x 21 x 29	40 x 21 x 29	52 x 21 x 29
PACKED WEIGHT (lbs)	77	104	135
COMPLIES WITH SPEC	NSF/ETL	NSF/ETL	NSF/ETL

Note: Output performance figures quoted are dependant on various factors.

Website: www.anvilworld.com

