



# COUNTERTOP FRYER

201b

## COUNTERTOP FRYER

*"Anvils deep fat fryers are designed to create a delicious variety of crisp fried food with minimum fuss. Delight your customers with french fries, chicken, fish, seafood, etc."*

### APPLICATION

- IDEAL FOR USE IN RESTAURANTS, TAKE AWAYS, CANTEENS, ETC.

### CONSTRUCTION

- DOUBLE PAN FOR SEPARATION OF FOOD TYPES OR USE ONE PAN WHEN QUIET AND BOTH WHEN BUSY
- HINGED ELEMENT BOXES WITH 2 STAGE LOCKING MECHANISM
- PILOT LIGHT INDICATES WHEN ELEMENTS ARE ENERGISED
- LIFT-OUT, ONE-PIECE STAINLESS STEEL TANKS WITH CARRYING HANDLES FOR EASE OF CLEANING

### HEATING

- VARIABLE HEAT CONTROL FROM 122°F - 374°F
- REACHES FRYING TEMPERATURES FAST
- RECOVERS TO OPERATING TEMPERATURE QUICKLY BETWEEN LOADS

### ACCESSORIES

- NIGHT COVERS
- NICKEL-PLATED MILD STEEL WIRE BASKETS

### SAFETY FEATURES

- AUTOMATIC CUT-OUT AT 390°F TO PREVENT OIL FIRE
- MICRO SWITCH DISCONNECTS POWER WHEN ELEMENT BOX IS REMOVED



Anvil reserves the right, without notice, to make changes and revisions to product specifications, materials and design, which in our opinion, will provide better performance, durability and efficiency.



ALL ANVIL EQUIPMENT COMES WITH A ONE YEAR WARRANTY ON COMPONENTS AND DEFECTIVE WORKMANSHIP

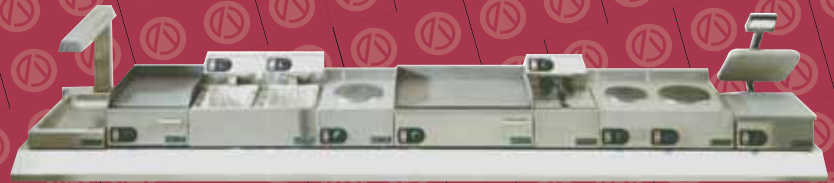

RESET BUTTON FOR SAFETY CUT OUT  
IF FRYING COMPOUND OVERHEATS

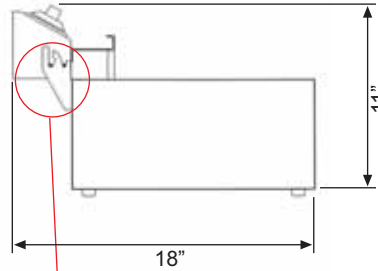
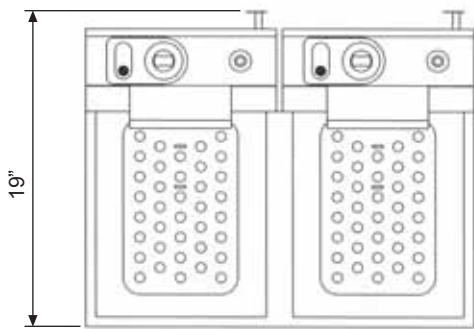
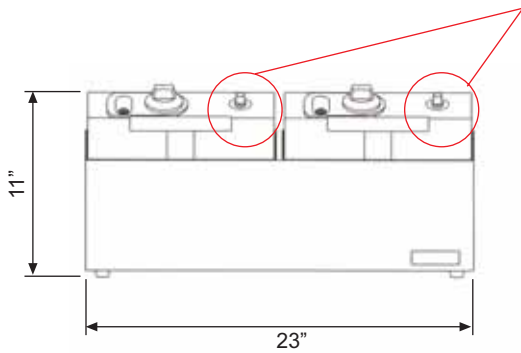

TILT UP ELEMENT HEAD WITH SAFETY LOCK DEVICE

## COUNTERTOP FRYER

MODELS:  
FFA7020  
FFA7120  
FFA8020  
FFA8120

**NOTE:**

When viewing the appliance from the front in its usual operating position, the width (W) of the product is the total distance from left to right; the depth (D) of the product is the total distance from front to back; the height (H) is the total distance from the bottom of the product to the top

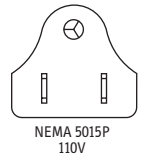
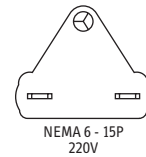

DESCRIPTION	FRYER 20lb	FRYER 20lb	ACCESSORIES
TWIN BASKETS	FFA7020	FFA8020	FFB2250 FRYER BASKET LARGE
SINGLE BASKETS	FFA7120	FFA8120	
VOL. OF OIL (l)	10	10	FFB1250 FRYER BASKET SMALL
VOL. OF OIL (lbs)	20	20	
± FRENCH FRIES (lbs/hr)	20	34	FFC0001 NIGHT LID LARGE
VOLTAGE (V)	110	220	
POWER (kW)	2 x 1.8	2 x 2.5	FFC0002 NIGHT LID SMALL
DIMENSIONS (in) (W x D x H)	23 x 19 x 11	23 x 19 x 11	
BOX DIMNS (in) (W x D x H)	25 x 21 x 13	25 x 21 x 13	
PACKED WEIGHT (lbs)	26	26	
COMPLIES WITH SPEC	UL 197	UL 197	

Note: Output performance figures quoted are dependant on various factors.

Manufactured by:  
Scientific Engineering (Pty) Ltd  
South Africa  
Website: [www.anvilworld.com](http://www.anvilworld.com)



FFA\_ANVIL\_USA\_03