



COUNTERTOP FRYER

101b

COUNTERTOP FRYER

"Anvils deep fat fryers are designed to create a delicious variety of crisp fried food with minimum fuss. Delight your customers with french fries, chicken, fish, seafood, etc."

APPLICATION

- IDEAL FOR USE IN RESTAURANTS, TAKE AWAYS, CANTEENS, ETC.

CONSTRUCTION

- HINGED ELEMENT BOX WITH 2 STAGE LOCKING MECHANISM
- FITS INTO TIGHT COUNTER SPACES
- PILOT LIGHT INDICATES POWER ON
- LIFT-OUT, ONE-PIECE STAINLESS STEEL TANK WITH CARRYING HANDLES FOR EASE OF CLEANING

HEATING

- VARIABLE HEAT CONTROL FROM 122°F - 374°F
- REACHES FRYING TEMPERATURES FAST
- RECOVERS TO OPERATING TEMPERATURE QUICKLY BETWEEN LOADS

ACCESSORIES

- NIGHT COVER
- NICKEL-PLATED MILD STEEL WIRE BASKET

SAFETY FEATURES

- AUTOMATIC CUT-OUT AT 390°F TO PREVENT OIL FIRE
- MICRO SWITCH DISCONNECTS POWER WHEN ELEMENT BOX IS REMOVED



Anvil reserves the right, without notice, to make changes and revisions to product specifications, materials and design, which in our opinion, will provide better performance, durability and efficiency.



ALL ANVIL EQUIPMENT COMES WITH A ONE YEAR WARRANTY ON COMPONENTS AND DEFECTIVE WORKMANSHIP

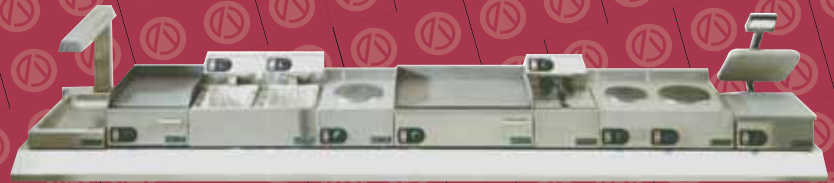

**COUNTERTOP
FRYER**

MODELS:
FFA7010
FFA7110
FFA8010
FFA8110

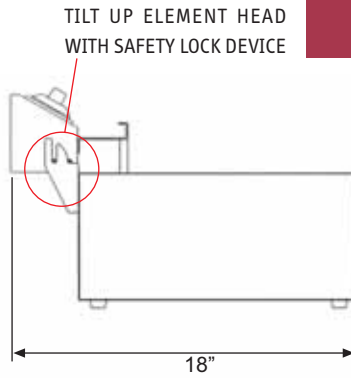
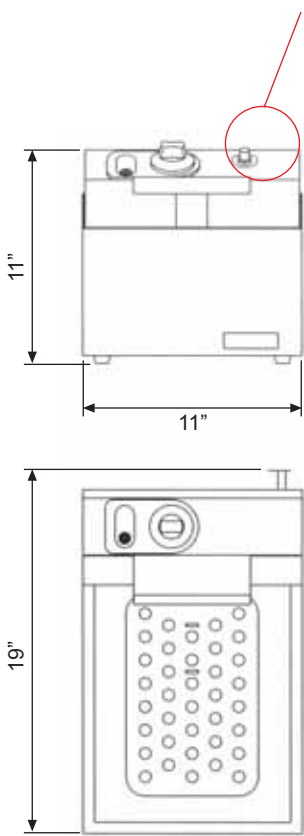

NOTE:
When viewing the appliance from the front in its usual operating position, the width (W) of the product is the total distance from left to right ; the depth (D) of the product is the total distance from front to back ; the height (H) is the total distance from the bottom of the product to the top

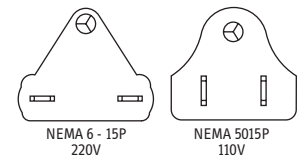

DESCRIPTION	FRYER 10lb	FRYER 10lb	ACCESSORIES
TWIN BASKETS	FFA7110	FFA8110	FFB2250 FRYER BASKET LARGE
LARGE BASKET	FFA7010	FFA8010	
VOL. OF OIL (l)	5	5	FFB1250 FRYER BASKET SMALL
VOL. OF OIL (lbs)	10	10	
± FRENCH FRIES (lbs/hr)	10	17	FFC0001 NIGHT LID LARGE
VOLTAGE (V)	110	220	
POWER (kW)	1.8	2.5	FFC0002 NIGHT LID SMALL
DIMENSIONS (in) (W x D x H)	11 x 19 x 11	11 x 19 x 11	
BOX DIMNS (in) (W x D x H)	13 x 21x 13	13 x 21x 13	
PACKED WEIGHT (lbs)	15	15	
COMPLIES WITH SPEC	UL 197	UL 197	

Note: Output performance figures quoted are dependant on various factors.

Manufactured by:
Scientific Engineering (Pty) Ltd
South Africa
Website: www.anvilworld.com



FFA_ANVIL_USA_01