



BEVERAGE-AIR

3779 Champion Blvd., Winston-Salem, NC 27105
1-888-845-9800 Fax# 1-336-245-6453
<http://www.Beverage-Air.com>

Commercial Refrigeration Equipment General Specification

3 Year Parts/Labor Warranty Additional 2 Year Compressor Warranty

WTR SHALLOW DEPTH SERIES WORKTOP UNITS

Compact shallow depth worktop refrigerators with stainless steel exterior, heavy duty construction including durable worktop, 120° stay-open field reversible doors with cartridge style hinges & snap-in door gaskets.

CABINET CONSTRUCTION

Models are designed to fit in limited spaces with stainless steel exterior and aluminum interior. Heavy duty construction with durable 1 1/2" thick 16 gauge stainless steel worktop and 2" thick CFC and HCFC-free foamed-in-place polyurethane insulation. Cartridge style hinges with black anodized aluminum pull style door handles and 120° stay-open door feature.

Snap-in-place vinyl magnetic gaskets.

Standard options: 6" high casters* and 2 steel wire epoxy coated shelves per door section.

REFRIGERATION

Balanced interior forced air system with high humidity evaporator coils. Refrigeration system operates at 36° to 38°F for optimal food preservation. Refrigerators utilize environmentally friendly R134a refrigerant, which is CFC and HCFC-free providing full compliance with environmental safety standards.

ELECTRICAL

Units wired at factory and ready for connection to a 115/60/1 phase, 15 amp dedicated outlet. 8' long cord and plug set included.

AVAILABLE ACCESSORIES

- Shelf dividers
- Overshelf kits
- Composite and poly cutting boards

OPTIONAL UPGRADES

- LED lighting (glass door refrigerators)
- Stainless steel interior
- Door locks
- Left hand hinge door(s) (excludes WTR34Y)
- Left hinge door(s) & 3" casters packed
- Door thermometer

Item No. _____
Quantity _____

SHALLOW DEPTH WORKTOP REFRIGERATORS FOOD PREPARATION SERIES

MODELS:
WTR20Y
WTR34Y



WTR20Y



WTR34Y

*Units shown with 6" casters;
3" casters or 6" legs optional;
no charge when specified on order*

ELECTRICAL CONNECTION

Units pre-wired at factory and include 8' long cord and plug set.



115/60/1
NEMA-5-15P



Available From:

Model Specified _____	Store# _____
Location _____	Quantity _____



BEVERAGE-AIR

**Shallow Depth
Worktop Refrigerators**
Models: WTR20Y, WTR34Y

MODEL	WTR20Y	WTR34Y
EXTERNAL DIMENSIONAL DATA		
Length Overall (inches)	20"	34"
Length Overall (mm)	508	864
Depth Overall (inches) - Includes handle	22 17/32"	22 23/32"
Depth Overall (mm) - Includes handle	572	577
Height Overall— on 6" casters (inches)	31 9/32"	31 9/32"
Height Overall—on 6" casters (mm)	795	795
Depth with Door Open 90 °	40 1/2"	38"
Clear Door Opening (inches)	15 3/4" x 18 3/16"	13/ 1/8" x 18"
Number of doors	1	2
INTERNAL DIMENSIONAL DATA		
NET Capacity (cubic ft.)	2.7	5.5
NET Capacity (Liters)	77	156
Internal Length Overall (inches)	16"	29 3/8"
Internal Length Overall (mm)	406	746
Internal Depth Overall (inches)	13"	17"
Internal Depth Overall (mm)	330	432
Internal Height Overall (inches)	19"	19"
Internal Height Overall (mm)	483	483
Number of shelves	2	4
ELECTRICAL DATA		
Full Load Amperes 115/60/1	3.0	4.0
REFRIGERATION DATA		
Horsepower	1/6	1/5
WEIGHT DATA		
Gross Weight (Crated lbs)	119	165
Gross Weight (Crated kg)	54	75

PLAN VIEWS

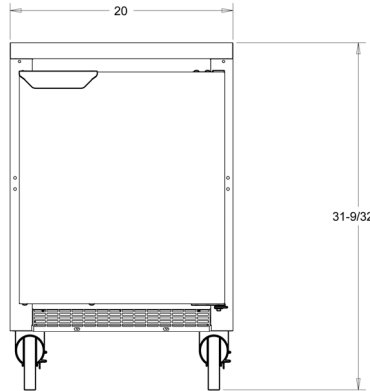

WTR20Y FRONT

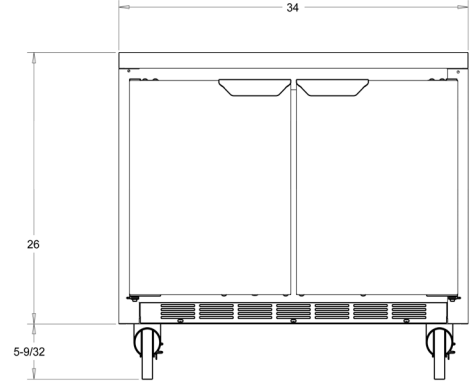

WTR34Y FRONT

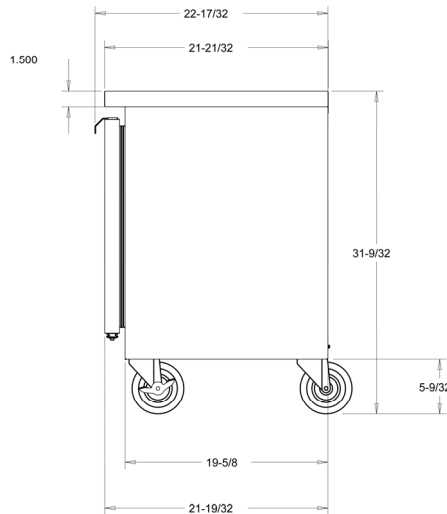

WTR20Y END

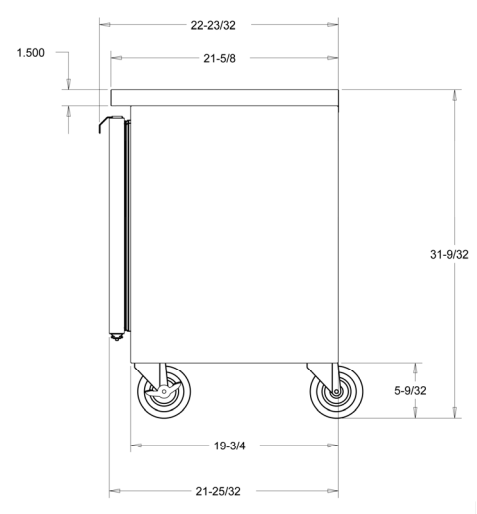

WTR34Y END

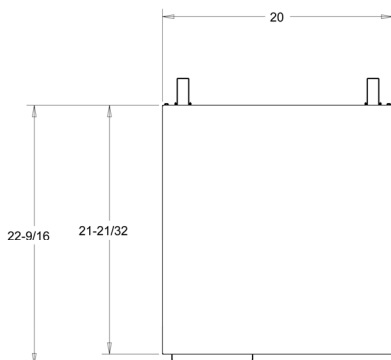

WTR20Y TOP

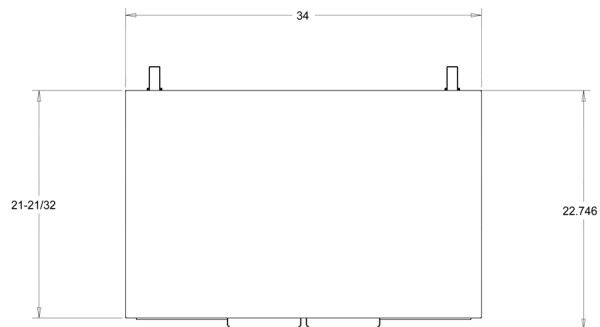

WTR34Y TOP



BEVERAGE-AIR® CORPORATION

3779 Champion Blvd. • Winston-Salem, NC 27105 USA • (336) 245-6400 • Fax (336) 245-6453 • (888) 845-9800 • www.beverage-air.com

Specifications are subject to change without prior notice. 5/13